



T240 Autotransformer



Installation and Operation Guide

T240 Autotransformer

Table of Contents

Section	Description	Page
1.	INTRODUCTION	1
	The T240 Autotransformer	1
2.	INSTALLATION	2
	Installation	2
	Required Tools	2
	Mounting	2
	Wiring	4
	Service Crimps	4
	Connection Points	5
	Step-up Configuration	8
	Deep Well Pump Wiring	9
	Step-Down Configuration	10
	Step-Down Connection of Stacked-pair Inverters	11
	Generator Output Balancing Autotransformer	12
	Single 120 volt AC Load	12
	Dual 120 volt AC Loads	13
	Optional Circuit Breakers	16
	Wiring Check	17
3.	OPERATION	18
4.	SERVICE INFORMATION	19
5.	SPECIFICATIONS	20
6.	WARRANTY	21

IMPORTANT SAFETY INSTRUCTIONS

This manual contains important safety instructions that should be followed during the installation and maintenance of this product.

To reduce the risk of electrical shock, and to ensure the safe installation and operation of this product, the following safety symbols have been placed throughout this manual to indicate dangerous conditions and important safety instructions.



WARNING - A dangerous voltage or condition exists in this area. Use extreme caution when performing these tasks.

AVERTISSEMENT - Une tension ou condition dangereuse existe dans cette zone. Faire preuve d'extrême prudence lors de la réalisation de ces tâches.



CAUTION - This procedure is critical to the safe installation or operation of the unit. Follow these instructions closely.

ATTENTION - Cette procédure est essentielle à l'installation ou l'utilisation de l'unité en toute sécurité. Suivre ces instructions de près.

NOTE - This statement is important. Follow instructions closely.



NOTE - Cette déclaration est importante. Suivre les instructions de près.

- All electrical work must be done in accordance with local, national, and/or international electrical codes.
- Before installing or using this device, read all instructions and cautionary markings located in the T240 and the manual.
- Do not expose this unit to rain, snow or liquids of any type. This product is designed only for indoor mounting.
- To reduce the chance of short-circuits when installing or working with this product, use insulated tools.
- Remove all jewelry such as rings, bracelets, necklaces, etc., while installing this system. This will greatly reduce the chance of accidental exposure to live circuits.

- This product contains no user-serviceable parts. Do not attempt to repair this unit.
- Do not mount this device in unventilated enclosures or in an engine compartment.
- Protect the device from splashing when used in vehicular applications.
- To reduce risk of electric shock, disconnect all wiring before attempting any maintenance or cleaning.
- Additional AC disconnects may be required as part of the system installation. Consult local and national electrical code requirements.
- Over-current Protection, provided by a 25 amp circuit breaker, protects the AC input/output wiring. This circuit breaker is branch circuit rated and has a 10,000 AIC rating, suitable for residential and commercial applications.
- This unit is designed to be horizontally wall mounted.
- The AC input and output neutral conductors are not connected (bonded) to the chassis.
- The AC input and output HOT conductor are not isolated from each other.
- The chassis housing of the T240 must be connected to a permanent grounding system as required by the National Electric Code, ANSI/NFPA 70-1996. This is the responsibility of the system installer. A grounding terminal strip is provided for connection of equipment grounding conductors.
- UL rated as an indoor enclosure.
- UL listed for sale in the U.S. and Canada under Photovoltaic Power System Accessories (UL1741) and Canadian standard for general use power supplies (CSA C22.2 No. 107.1-95).

SAVE THESE INSTRUCTIONS

Disclaimer of Liability

Since the use of this manual and the conditions or methods of installation, operation, use and maintenance of the unit are beyond the control of Trace Engineering, the Company does not assume responsibility and expressly disclaims liability for loss, damage, or expense arising out of or any way connected with such installation, operation, use, or maintenance.

The T240 Autotransformer is designed to step-up 120 volt AC to 240 volt AC or to step-down 240 volt AC into two 120 volt AC circuits. The T240 contains two identical windings that can be used to step-up, step-down, or balance the output voltage of an AC power source (such as an inverter, generator or conventional AC source) to an AC load. The unit is sized to take advantage of Trace Engineering's inverter/charger line. The exceptionally high efficiency of the T240 Autotransformer makes it ideal for voltage conversion from an inverter, generator or conventional AC source.

The T240 Autotransformer utilizes a highly-efficiency transformer constructed of high temperature materials and M-6 grade steel laminations, meeting UL Class-H standards.

The unit is housed in a powder coated, steel enclosure, suitable for indoor installations and contains knockouts for 3/4 inch and 1 inch conduit connections and additional breakers. One 25 amp dual breaker is supplied with the T240. Up to six additional Square D QOU breakers can be added for additional input/output wiring protection and control.



Figure 1
T240 Autotransformer

2.0 INSTALLATION

Installation

Required Tools

- Wire strippers
- Phillips screw driver
- Slotted screw driver
- Torque wrench

Mounting

Place the T240 Autotransformer in a convenient location, close to the input source (inverter, generator or utility). The T240 must be mounted horizontally on a flat surface (such as a wall) in a clean, dry environment. Do not mount the autotransformer where it will be exposed to the weather or in a wet location.



NOTE: The T240 weighs approximately 50 pounds. Use appropriate wall anchors or backing material (plywood, 2 x 4's, etc.) that will support its weight.

Procedure:

- Use a level and mark the location for mounting the unit on the wall.
- Measure out the four mounting screw holes according to Figure 3.
- Drill out the mounting holes using a #18 (0.170 inch) drill bit.
- Remove the front cover of the autotransformer by removing the four Phillips screws. Do not lose the screws!
- Use a #10 x 3/8 (or 1/2) inch long screw and washer (and appropriate anchors if necessary) and mount the autotransformer securely to the wall or backing material (plywood, 2 x 4's, etc.).
- Remove the appropriate knockouts for the conduit. Install the conduit between the autotransformer and input source (inverter, generator, etc.) and output to load. Use separate conduit for input and output wiring.

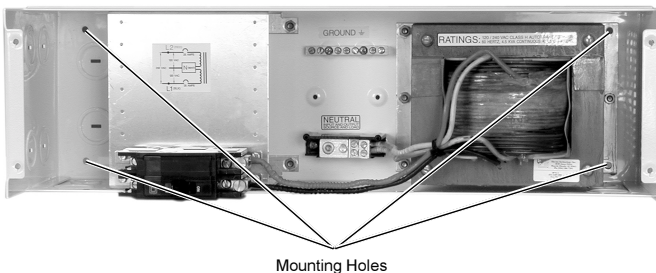

Figure 2
Mounting Holes

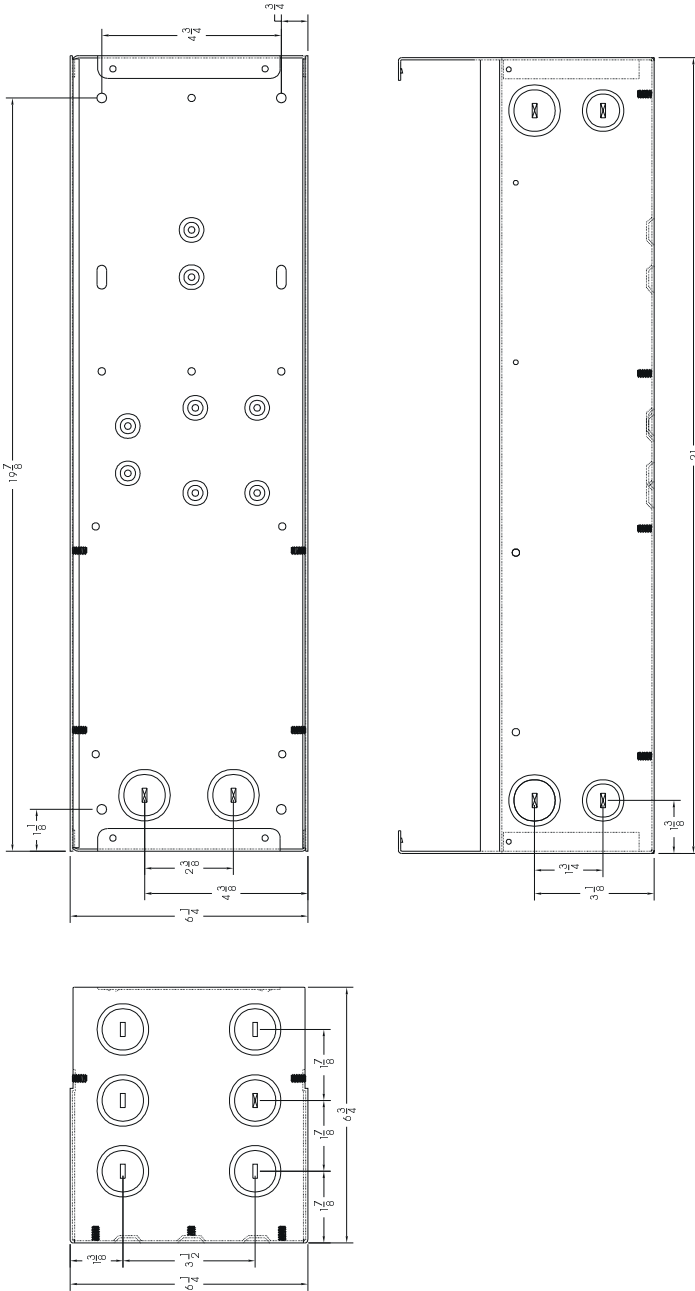

Figure 3
Installation Drawing

2.0 INSTALLATION

Wiring



WARNING: WIRING SHOULD BE PERFORMED ONLY BY QUALIFIED PERSONS.



WARNING: BEFORE WIRING THE AUTOTRANSFORMER, ENSURE THAT ALL SOURCES OF POWER ARE DISCONNECTED. NEVER WORK ON A LIVE CIRCUIT.



CAUTION: THE CONFIGURATION OF THE AUTOTRANSFORMER IS FOR STEP-UP, STEP-DOWN OR CURRENT BALANCING. IT DOES NOT PROVIDE ISOLATION BETWEEN INPUT AND OUTPUT. DO NOT USE THE AUTOTRANSFORMER AS AN ISOLATION DEVICE.



NOTE: All source connections (inverter, generator or utility) are connected to the left-hand side of the installed circuit breaker (see illustrations). All loads connect to the service crimp on the right-hand side of the breaker.

Service Crimps

The service crimps provide a convenient means to connect the autotransformer. Do not use the screw terminals on the breakers for making connections. Do not remove factory wiring.

- Pull back the insulation on the TRANSFORMER wire so it is exposed inside the service crimp.
- Strip off approximately 1/2 inch of the insulation from the wire to be installed and insert the bare wire into the crimp.
- Slide the crimp up to the circuit breaker terminal as far as it will go.
- Place the wire in the crimp and ensure the existing wire's insulation is fully exposed. Torque the crimp screw to 45 inch/pounds.
- After torquing, ensure the service crimp is tight on both wires and is not able to twist or be moved.



CAUTION: UNUSED SERVICE CRIMPS SHOULD BE TIGHTENED TO THE EXISTING WIRE AND TAPED, SO IT CAN NOT SHORT TO OTHER TERMINALS OR THE CASE.

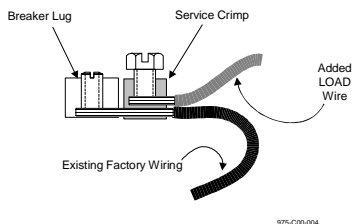

Figure 4
Installation Drawing

Connection Points

The connection points for input/output wiring is as follows:

- All 240 volt AC (input or output) wires connect to the left-hand side of the breaker, points A and C (Figures 6 and 7).
- All 120 volt AC wires connect to the service crimps located on the breaker, points B and D (Figures 6 and 7).
- All neutral wires connect to the NEUTRAL block in the T240.
- All ground wires connect to the GROUND block in the T240.
- The ganged circuit breaker used in the T240 opens both circuit breakers if either one receives a current draw in excess of its rating (i.e., 25 amps).

Any exceptions are noted in the procedure.



NOTE: Due to continued product improvement, parts availability, etc., photographs used in this manual may vary slightly from actual current production models.

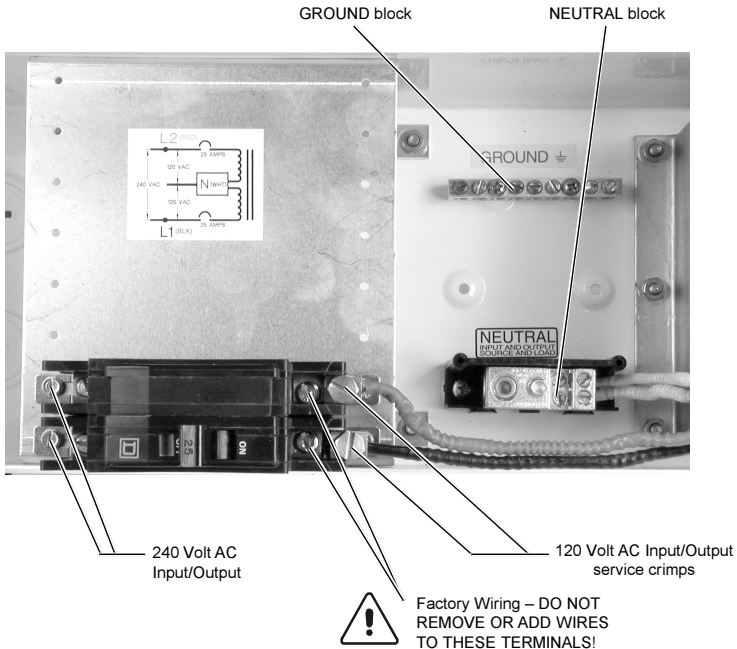

Figure 5
Step-up Configuration Connections

2.0 INSTALLATION

Connection Identification Points (continued)

Figures 6 and 8 identify the wiring points in the T240 Autotransformer:

- A** Only 240 volt AC (L1) input/output connections are made on this circuit breaker terminal.
 - B** This is the service crimp on the lower ganged breaker. Only 120 volt AC input/output wires connect to this service crimp.
 - C** Only 240 volt AC (L2) input/output connections are made on this circuit breaker terminal.
 - D** This is the service crimp on the upper ganged breaker. Only 120 volt AC input/output wires connect to this service crimp.
- GROUND** This is the ground block contained in the T240. All ground wires connect to this block for both source and load.
- NEUTRAL** This is the neutral block contained in the T240. All neutral wires connect to this block for both source and load (except as noted in the procedures).

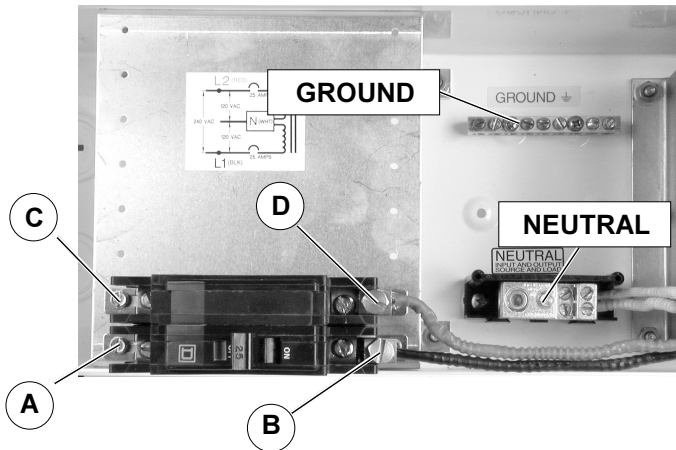

Figure 6
Connection Point Identification

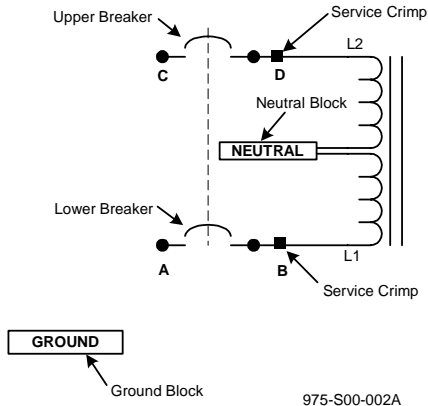

Figure 7
Connection Point Identification Schematic

2.0 INSTALLATION

Step-up Configuration

This configuration allows for a 240 volt AC load to be supplied from a 120 volt AC input source. The voltage output of the autotransformer doubles (from 120 to 240 volts AC) and the total output current available is one half.

Procedure

The wire terminals accept wire sizes from #14 AWG to #2 AWG. Use the proper size wire for the load connected.

120 Volt AC Input (source)



NOTE: Refer to the previous instructions on connecting wires to the service crimp.

- Connect the 120 volt AC HOT wire (from an inverter, generator or utility) to service crimp (point B) of the breaker as shown in Figure 8.
- Connect the neutral wire (from an inverter, generator or utility) to the NEUTRAL block in the autotransformer.
- Connect the ground wire (from an inverter, generator or utility) to the GROUND block in the autotransformer.

240 Volt AC Outputs (load)

- Connect a black wire from the L1 connection on the breaker (point A), to the load's L1 connection.
- Connect a red wire from the L2 connection on the breaker (point C), to the load's L2 connection.
- Connect a white wire from the NEUTRAL block in the autotransformer to the load's neutral connection.
- Connect a green wire from the GROUND block in the autotransformer to the load's ground connection.

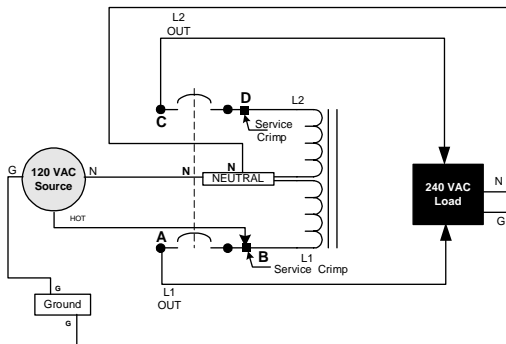

975-S00-003

Figure 8
Step-up Configuration Schematic

Deep Well Pump Wiring

This wiring configuration allows the control switch for the pump to be connected between the 120 volt AC source and the HOT input of the T240. In this arrangement, there is no transformer idle power consumption when the switch is open and the pump is not running. The control switch can be either a float, pressure or manual type.

Procedure

120 Volt AC Inputs (source)



NOTE: Refer to the previous instructions for connecting wires to the service crimp on page 4 and Figure 4.

- Connect the pump's control or pressure switch to the service crimp (point B) on the lower breaker.
- Connect the 120 volt AC HOT wire (from an inverter, generator, or utility) to the free end of the control switch.
- Connect the neutral wire (from an inverter, generator or utility) to the NEUTRAL block in the autotransformer.
- Connect the ground wire (from an inverter, generator or utility) to the GROUND block in the autotransformer.

240 Volt AC Outputs (load)

- Connect a black wire from the L1 connection on the breaker (point A), to the pump's L1 connection.
- Connect a red wire from the L2 connection on the breaker (point C), to the pump's L2 connection.
- Connect a white wire from the NEUTRAL block in the autotransformer to the pump's neutral connection.
- Connect a green wire from the GROUND block in the autotransformer to the pump's ground connection.

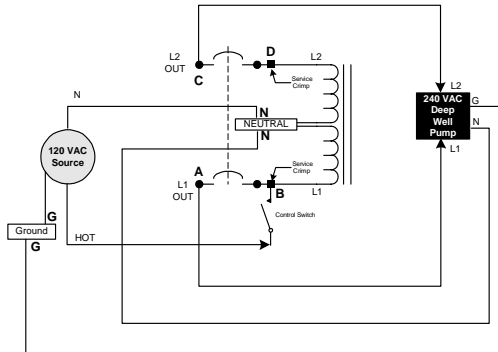

975-S00-005

Figure 9
Control Switch Wiring for Deep Well Pump

2.0 INSTALLATION

240 Volt AC Source–120 Volt AC to Loads (Step-down Configuration)

This configuration allows a 120 volt AC load to be supplied from a 120/240 volt AC input source such as a utility grid. The voltage output of the autotransformer halves (from 240 to 120 volts AC) and the total output current available for the 120 volt AC output doubles. This arrangement is useful for splitting the current of a battery charger between each leg of the 240 volt AC source, reducing losses in the wiring. This is especially important in long cable runs or when charging from a 120/240 volt AC output generator.

240 Volt AC Input (source)

- Connect the L1 AC HOT wire (from the utility grid) to point A on the lower breaker as shown in Figure 10.
- Connect the L2 AC HOT wire (from the utility grid) to point C on the upper breaker as shown in Figure 10.
- Connect the neutral wire (from the utility grid) to the NEUTRAL block in the autotransformer.
- Connect the ground wire (from the utility) to the GROUND block in the autotransformer.

120 Volt AC Output (load)

- Connect a black wire from the service crimp (point B), to the load's HOT connection.



NOTE: Refer to the previous instructions located on page 4 and Figure 4 for connecting wires to the service crimp.

- Connect a white wire from the NEUTRAL block in the autotransformer to the load's neutral connection.
- Connect a green wire from the GROUND block in the autotransformer to the load's ground connection.

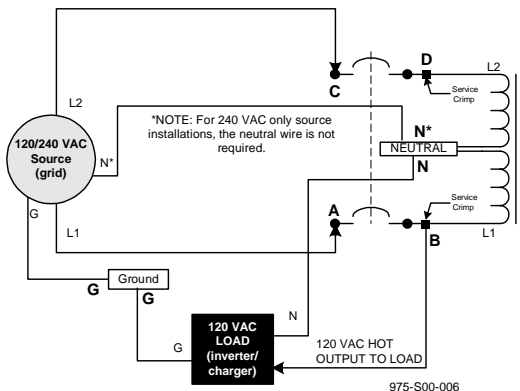

Figure 10
Step-down Configuration Schematic

Step-down Connection of Stacked-pair Inverters

The T240 can also be used to step down the voltage from a stacked pair of DR or SW Series inverters. In this configuration, the neutral of the inverters must be isolated from the neutral block of the T240 Autotransformer, or the inverters may over-current trip when they synchronize to an AC generator. This configuration may not be in compliance with the NEC. Consult your local and national electrical codes for requirements. This configuration provides double the output current at 120 volts AC.

Procedure

Inverter Inputs to T240

- Connect the HOT output of Inverter #1 to point A on the lower breaker.
- Connect the HOT output of Inverter #2 to point C on the upper breaker.
- Connect the ground wire from the inverters to the GROUND block in the T240.

T240 Output to 120 Volt AC Load

- Connect the ground wire from the load to the GROUND block in the T240.
- Connect the neutral wire from the load to the NEUTRAL block in the T240.
- Connect the HOT wire (120 volt AC) from the load to the service crimp on lower breaker (point B).
- Connect the inverters as specified in the inverter's operation manual for stacked (120/240 volt AC) operation.

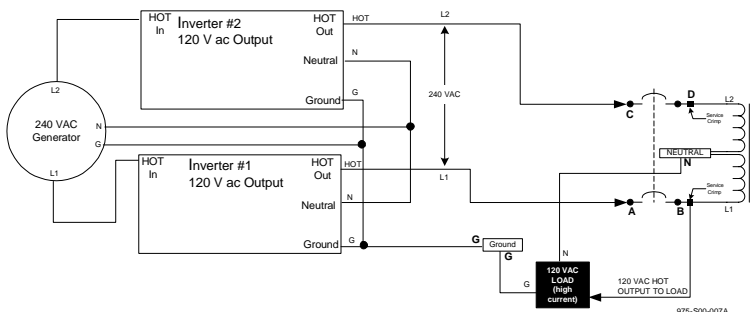

Figure 11
Step-down Configuration Schematic (Dual Inverters)

2.0 INSTALLATION

Generator Output Balancing Autotransformer

Single 120 Volt AC Load

This configuration allows the 120/240 volt AC generator output to be equally divided (balanced) between its L1 and L2 outputs. In this example, the generator is using both its L1 and L2 outputs to supply a high current 120 volt AC load. Balancing the generator in this way improves generator performance and life, plus results in higher battery charge rates.

Procedure

- Connect the L1 output of the generator to the lower breaker (point A).
- Connect the L2 output of the generator to the upper breaker (point C).
- Connect the ground wire from the generator to the T240 GROUND block.
- Connect the neutral wire from the generator to the T240 NEUTRAL block.
- Connect the inverter's 120 volt AC input to the service crimp on the lower breaker (point B).
- Connect a ground wire from the inverter to the GROUND block in the T240.
- Connect a neutral wire from the inverter to the NEUTRAL block in the T240 .
- Follow the instructions for wiring the inverter to the loads as specified in the inverter's operation manual.

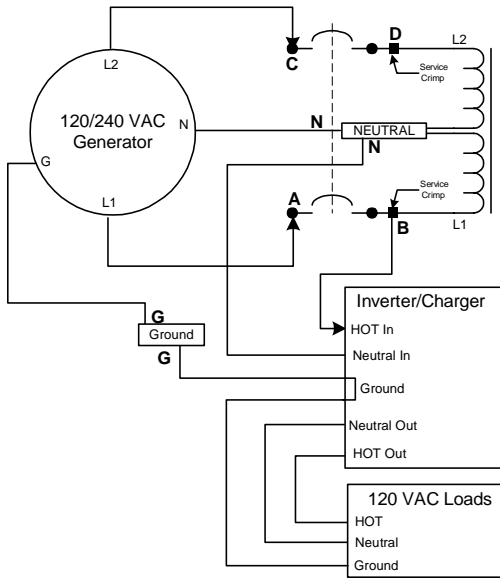

975-S00-008

Figure 12
Generator Output Balancing (single 120 volt AC load)



NOTE: The ability of the T240 to balance the load depends upon the generator's windings and voltage regulation it receives on each leg. If the voltages are not equal, or if there are other loads on the legs, then the currents in each leg will not be equal.

To absolutely equal the load, disconnect the neutral connection of the T240 to the generator. This un-bonds the output neutral from ground. This neutral should be considered as a "HOT" wire and treated as such. This configuration may not be compliant with the NEC, but will "balance" the load on the 240 volt AC side.

2.0 INSTALLATION

Generator Output Balancing Autotransformer

Dual 120 Volt AC Loads

This configuration allows the 120/240 volt AC generator output to be equally divided (balanced) between its L1 and L2 outputs. In this case, the generator is using both its L1 and L2 outputs to supply two separate 120 volt AC loads. If one leg of the generator is pulling a heavier load than the other, both legs equally divide the current, thereby balancing the generator's output.

Procedure

240 Volt AC Inputs From the Generator

- Connect the L1 (HOT) output of the generator to the terminal on the lower breaker (point A).
- Connect the L2 (HOT) output of the generator to the terminal on the upper breaker (point C).
- Connect the ground wire from the generator to the GROUND block in the T240.
- Connect the neutral wire from the generator to the NEUTRAL block in the T240.

120 Volt AC Outputs to Inverters or Loads

- Connect the 120 volt AC input wire for Inverter #1 to the service crimp (point B) on the lower inverter.
- Connect the ground wire from the inverter #1 to the GROUND block in the T240.
- Connect the neutral wire from Inverter #1 to the NEUTRAL block in the T240.
- Connect the 120 volt AC input wire for Inverter #2 to the service crimp (point D) on the upper inverter.
- Connect the ground wire from the inverter #2 to the GROUND block in the T240.
- Connect the neutral wire from Inverter #1 to the NEUTRAL block in the T240.
- Connect the inverter's outputs as specified in the inverter's operation manual.

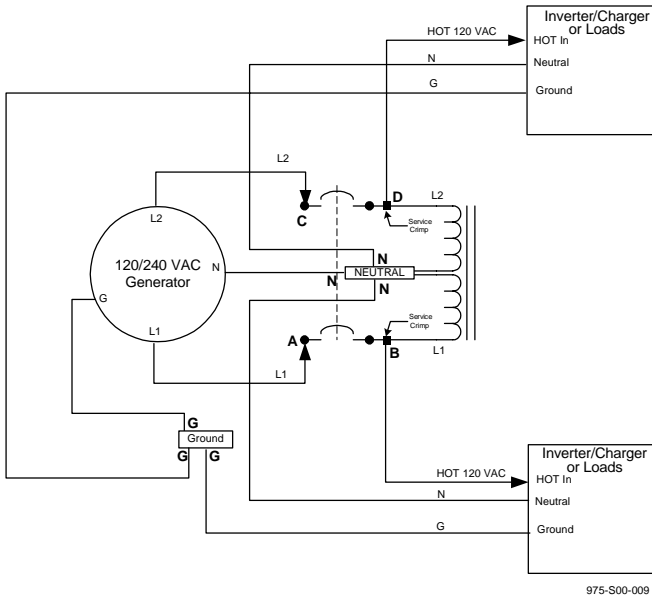

Figure 13
Generator Output Balancing (dual 120 volt AC load)

2.0 INSTALLATION

Optional Circuit Breakers

Up to six additional Square D QOU circuit breakers can be installed in the T240 enclosure. Front panel knockouts and predrilled holes provide for easy mounting of additional breakers.

The example below shows these additional breakers used to protect and control six 120 volt AC loads. Different circuit configurations can be arranged depending upon your powering needs.

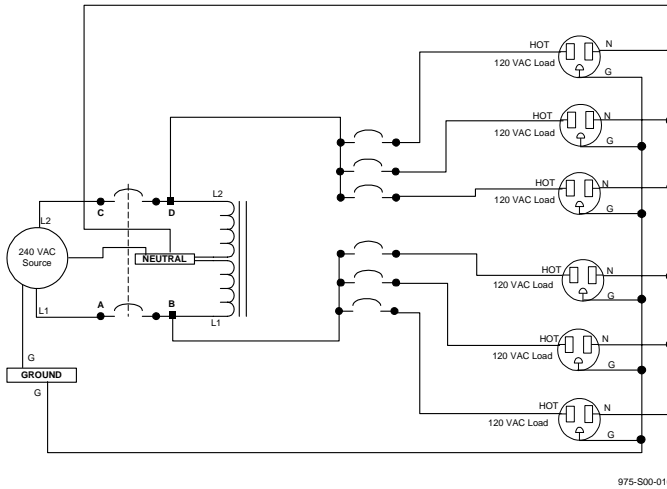

Figure 14
Step Down Arrangement Using Optional Breakers



NOTE: Provisions for connecting the additional neutral wires may need to be added.



NOTE: The T240 has not been listed with UL with additional breakers installed.

Wiring Check

Before powering the T240 Autotransformer, recheck all wiring and ensure it is connected to the proper terminals of the breaker or service crimps. Check that the ground and neutral connections are properly wired and tight. Use the schematics in this manual to trace the wire connections from the source to the T240 and to the load.

After all the wiring has been checked, install the front cover and secure it with the four Phillips screws removed in the beginning of the installation.

3.0 OPERATION

- Apply power from the source to the T240 Autotransformer.
- Switch the L1/L2 breaker to ON. The loads are now energized by the T240.



NOTE: The switch on the lower breaker controls both breakers. If either breaker receives an over-current condition, both breakers will trip.

- If additional branch circuit breakers are installed, switch them to ON if desired.

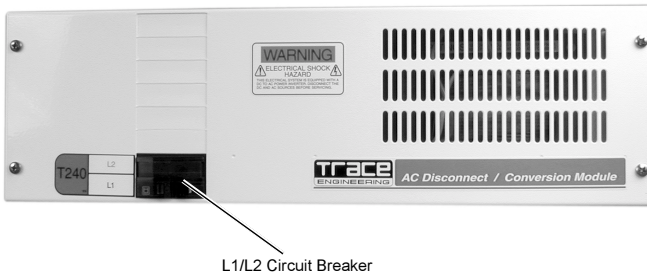

Figure 15
Circuit Breaker Location

4.0 SERVICE INFORMATION

Trace Engineering takes great pride in its products and makes every effort to ensure your unit fully meets your independent powering needs.

If your product needs repair, contact our Service department at: (360) 435-8826 ext. 2223 to obtain an RMA# and shipping information; or fax this page with the following information to: (360) 474-0616 or e-mail to: tracewarranty@traceengineering.com.

Please provide:

Model Number: _____
Serial Number: (if applicable) _____
Purchase Date: _____
Problem: _____

Include a telephone number where you can be reached during business hours and a complete return shipping address (P.O. Box numbers are not acceptable).

Name: _____
Address: _____
City: _____
State / Province: _____
Zip / Postal Code: _____
Phone: () _____
Country: _____

Register On-line

On-line warranty registration is available at: www.traceengineering.com/technical/warranty.



visit our website at: www.traceengineering.com

5.0 SPECIFICATIONS

Total Power Rating	3900 VA continuous
Input/Output Voltage	120/240 volts AC \pm 10%
Input/Output Frequency	60 Hz
Idle Power Consumption	< 12 W (typical)
Input/Output Circuit Breaker Rating	25 A 2 pole Square D QOU Branch Circuit Rated/10,000 AIC
Weight	39.4 lb (17.9 kg)
Shipping Weight	43.7 lb (19.8 kg)
Dimensions	6.3" H x 21" W x 7.0" D (16 cm x 53.3 cm x 17.8 cm)
Enclosure	Indoor, ventilated, steel chassis, powder coated white
Hookup Wire Size	#14 AWG to #2 AWG
Conduit Sizes	Knockouts for 3/4" and 1" conduit
Insertion Loss	< 4 VAC at 3900 VA
Approvals	UL1741, CSA C22.2 No. 107.1-95

Specifications @ 25 °C
Specifications subject to change without notice

Limited Warranty

Trace Engineering warrants its power products against defects in materials and workmanship for a period of two (2) years from the date of purchase, established by proof of purchase or formal warranty registration, and extends this warranty to all purchasers or owners of the product during the warranty period. Trace does not warrant its products from any and all defects:

- arising out of material or workmanship not provided by Trace Engineering or its Authorized Service Centers;
- when the product is installed or exposed to an unsuitable environment as evidenced by generalized corrosion or biological infestation;
- resulting from abnormal use of the product or use in violation of the instructions;
- in components, parts, or products expressly warranted by another manufacturer.

Trace Engineering agrees to supply all parts and labor to repair or replace defects covered by this warranty with parts or products of original or improved design, at the company's option. Trace Engineering also reserves the right to improve the design of its products without obligation to modify or upgrade those previously manufactured. Defective products must be returned to Trace Engineering or its Authorized Service Center in the original packaging or equivalent. The cost of transportation and insurance on items returned for service is the responsibility of the customer. Return transportation (UPS Ground or equivalent) as well as insurance on all repaired items is paid by Trace Engineering.

All remedies and the measure of damages are limited to the above. Trace Engineering shall in no event be liable for consequential, incidental, contingent, or special damages, even if Trace Engineering has been advised of the possibility of such damages. Any and all other warranties, expressed or implied, arising by law, course of dealing, course of performance, usage of trade or otherwise, including, but not limited to, implied warranties of merchantability and fitness for a particular purpose, are limited in duration for a period of two (2) years from the original date of purchase.

Some states or counties do not allow limitations on the term of an implied warranty, or the exclusion or limitation of incidental or consequential damage, which means the limitations and exclusions of this warranty may not apply to you. Even though this warranty gives you specific legal rights, you may also have other rights which vary from state to state.



5916 - 195th Street N.E., Arlington, WA 98223 Phone: (360) 435-8826 Fax: (360) 435-2229

visit our website at: www.traceengineering.com



5916 - 195th Street N.E., Arlington, WA 98223 Phone: (360) 435-8826 Fax: (360) 435-2229

visit our website at: www.traceengineering.com