

**xantrex**

*Smart Choice for Power*

# Installation Guide



## **Grid Tie Interface (GTI)**

SW Series

SW4024, SW4048, SW5548

## About Xantrex

Xantrex Technology Inc., is a world-leading supplier of advanced power electronics and controls with products from 50 watt mobile units to 1 MW utility-scale systems for wind, solar, batteries, fuel cells, microturbines, and backup power applications in both grid-connected and stand-alone systems. Xantrex products include inverters, battery chargers, programmable power supplies, and variable speed drives that convert, supply, control, clean, and distribute electrical power.

## Trademarks

Trace and Xantrex are registered trademarks of Xantrex International.

## Notice of Copyright

Grid Tie Interface (GTI) Installation Guide ©March 2002 Xantrex Technology Inc. All rights reserved.

## Disclaimer

While every precaution has been taken to ensure the accuracy of the contents of this guide, Xantrex International assumes no responsibility for errors or omissions. Note as well that specifications and product functionality may change without notice.

Since the use of this manual and the conditions or methods of installation, operation, use and maintenance of the unit are beyond the control of Xantrex Technology Inc., the company does not assume responsibility and expressly disclaims liability for loss, damage, or expense arising out of or any way connected with such installation, operation, use, or maintenance.

Due to continual improvement through product updates, photographs and/or illustrations used in this manual may not *exactly* match your unit. Xantrex Technology Inc., reserves the right to update this product without notice or releasing an updated manual when *fit, form or function* are not affected.

## Date and Revision

March 2002, Revision A

## Part Number

975-0041-01-02

## Contact Information

Web:	<a href="http://www.xantrex.com">www.xantrex.com</a>
Email:	<a href="mailto:dpm@xantrex.com">dpm@xantrex.com</a>
Phone:	360/435.8826
Fax:	360/435.2229

## IMPORTANT SAFETY INSTRUCTIONS

This manual contains important safety instructions that should be followed during the installation and maintenance of this product.

To reduce the risk of electrical shock, and to ensure the safe installation and operation of this product, the following safety symbols have been placed throughout this manual to indicate dangerous conditions and important safety instructions.



**WARNING - A DANGEROUS VOLTAGE OR CONDITION EXISTS IN THIS AREA. USE EXTREME CAUTION WHEN PERFORMING THESE TASKS.**

**AVERTISSEMENT - UNE TENSION OU CONDITION DANGEREUSE EXISTE DANS CETTE ZONE. FAIRE PREUVE D'EXTRÊME PRUDENCE LORS DE LA RÉALISATION DE CES TÂCHES.**

---



**CAUTION - This procedure is critical to the safe installation or operation of the unit. Follow these instructions closely.**

**ATTENTION - Cette procédure est essentielle à l'installation ou l'utilisation de l'unité en toute sécurité. Suivre ces instructions de près.**

---



**NOTE - This statement is important. Follow instructions closely.**

**NOTE - Cette déclaration est importante. Suivre les instructions de près.**

---

- All electrical work must be done in accordance with local, national, and/or international electrical codes.
- Before installing or using this device, read all instructions and cautionary markings located in the manual, and on the inverter, the batteries, and the PV array.
- Do not expose this unit to rain, snow, or liquids of any type. This product is designed only for indoor mounting.
- To reduce the chance of short-circuits use insulated tools when installing or working with the inverter, the batteries, or the PV array.
- Remove all jewelry while installing this system. This will greatly reduce the chance of accidental exposure to live circuits.

## **IMPORTANT SAFETY INSTRUCTIONS (Continued)**

- The unit contains more than one live circuit (inverter and utility grid). Power may be present at more than one source.
- This product contains no user-serviceable parts. Do not attempt to repair this unit.
- To reduce risk of electric shock, disconnect all wiring before attempting any maintenance or cleaning.
- Do not mount this device in unventilated enclosures.
- To reduce risk of electric shock, disconnect all wiring before attempting any maintenance or cleaning.
- Additional AC disconnects may be required as part of the system installation. Consult local and national electrical code requirements.
- This unit is designed to be horizontally wall mounted.
- The AC input and output neutral conductors are not connected (bonded) to the chassis.
- The AC input and output HOT conductor are not isolated from each other.
- The chassis housing of the GTI must be connected to a permanent grounding system as required by the National Electric Code, ANSI/NFPA 70-1996. This is the responsibility of the system installer. A grounding terminal lug is provided for connection of an equipment grounding conductor.
- CSA certified for sale in the U.S. under Photovoltaic Power Systems (UL1741).

## **SAVE THESE INSTRUCTIONS**

# Contents

IMPORTANT SAFETY INSTRUCTIONS .....	iii
<b>1.0 INTRODUCTION .....</b>	<b>1</b>
Introduction .....	1
Standard Features .....	4
Utility Interactive Mode .....	4
Bypass Mode .....	4
<b>2.0 INSTALLATION .....</b>	<b>5</b>
Pre-Installation .....	5
Required Tools and Materials .....	5
Removing the Top Cover .....	5
Mounting .....	6
Procedure .....	6
Wiring .....	8
AC Wiring for Single-Inverter Installations .....	8
Ground Wiring .....	10
Utility Grid AC Wiring to the GTI .....	12
Inverter AC Input Wiring to the GTI .....	14
Inverter AC Output Wiring to the GTI .....	16
GTI Wiring to the Sub-Panel .....	18
Communications Cable .....	20
AC Wiring for Dual-Inverter Installations .....	22
Ground Wiring .....	24
Utility Grid AC Wiring to Dual GTIs .....	26
Inverter AC Input and Output Wiring to the GTIs .....	28
GTI Wiring to the Sub-Panel .....	30
Connecting the Communications Cables for Dual Inverter Installations .....	30
AC Rewiring for Dual-Inverter Power Panel Installations .....	32
AC Rewiring for Power Module Installations .....	34
AC Rewiring for Power Module Installations (continued) .....	36
Wiring Check .....	37
Operating Stacked Inverters .....	37
Start-up and Test .....	37
<b>3.0 TROUBLESHOOTING .....</b>	<b>39</b>
<b>APPENDIX A – SPECIFICATIONS .....</b>	<b>A-1</b>
Electrical Specifications <sup>1</sup> .....	A-1
Mechanical Specifications .....	A-1
<b>APPENDIX B – PRODUCT AND SYSTEM INFORMATION ....</b>	<b>B-1</b>
Warranty .....	B-1
Return Material Authorization Policy .....	B-2
Return Material Procedure .....	B-2
Service Information .....	B-3

# List of Figures

Figure 1-1	Grid Tie Interface Flow Diagram .....	2
Figure 1-2	Grid Tie Interface Flow Diagram with External Manual Bypass Switch .....	3
Figure 1-3	Grid Tie Interface Unit .....	4
Figure 2-1	Removing the Top Cover .....	5
Figure 2-2	Mounting Holes .....	6
Figure 2-3	Dimensional Drawing (Not to scale) .....	7
Figure 2-4	GTI Circuit Board Enlargement.....	8
Figure 2-5	AC Input and Output Wiring for Single-Inverter Installations .....	9
Figure 2-5a	Ground Wiring for a Single-Inverter Installations .....	11
Figure 2-5b	Utility Grid AC Wiring to the GTI .....	13
Figure 2-5c	Inverter AC Input Wiring to the GTI .....	15
Figure 2-5d	Inverter AC Output Wiring to the GTI .....	17
Figure 2-5e	GTI Wiring to the Sub-Panel .....	19
Figure 2-6	GTI Communications Cable Location .....	20
Figure 2-7	Connecting the Communications Cable to the Circuit Board .....	21
Figure 2-8	Wiring Diagram for Dual-Inverter Installations .....	23
Figure 2-8a	Ground Wiring for Dual-Inverter Installations .....	25
Figure 2-8b	Utility Grid AC Wiring to Dual GTIs .....	27
Figure 2-8c	Inverter AC Input and Output Wiring to Dual GTIs .....	29
Figure 2-8d	GTI Wiring to the Sub-Panel .....	31
Figure 2-9	Re-wiring Power Panel Installations to include dual GTIs .....	33
Figure 2-10	Original Power Module Wiring .....	35
Figure 2-10a	Power Module Rewiring for dual GTI Installations .....	36

## INTRODUCTION

The Grid Tie Interface (GTI) is an integrated assembly used with the Trace™ SW Series II inverter/charger with Revision 4.2 (or higher) software. This new device provides active anti-islanding protection and reduces current Total Harmonic Distortion (THD) as required in UL-1741-2000.

The Grid Tie Interface is an accessory, which is connected between the grid, the AC loads, and the SW Series II inverter to optimize the “SELL” feature. While there is a small inductor in the GTI, this device is not a “filter”; rather it contains an additional control microprocessor, which connects to the SW Series II with a communications cable.

When the GTI is connected and the Inverter “SELL” mode is selected, the microprocessor of the GTI takes control of the SW Series II and operates the inverter “SELL” feature. The GTI affords a dedicated microprocessor and new, sophisticated control algorithms that are able to optimize the sell function.

The SW Series II with the GTI meets all power quality requirements of UL1741, including harmonic distortion, power factor, and anti-islanding requirements. In addition, it has increased the SW Series II's efficiency in SELL mode to within 1% of the impressive off-grid efficiency of the SW.

The GTI also contains an automatic transfer/shorting relay, which the SW Series II uses to disconnect the GTI from the circuit when it is not needed, for example when the SW Series II is charging batteries from the grid. This is also used to disconnect the GTI so that it does **NOT** represent a phantom load or parasitic loss to the system.

All new SW Series II units (manufactured since December of 2001) are equipped to allow the GTI to be installed in the field. The SW Series II inverter is Certified to UL1741 for off grid and backup power applications. The SW can be connected to the grid as a battery charger; however, it is **NOT** approved to use the SELL feature (net meter) without the GTI accessory. The GTI carries all necessary approvals and markings to allow a safety inspector to approve the installation for net metering.

# 1.0 INTRODUCTION

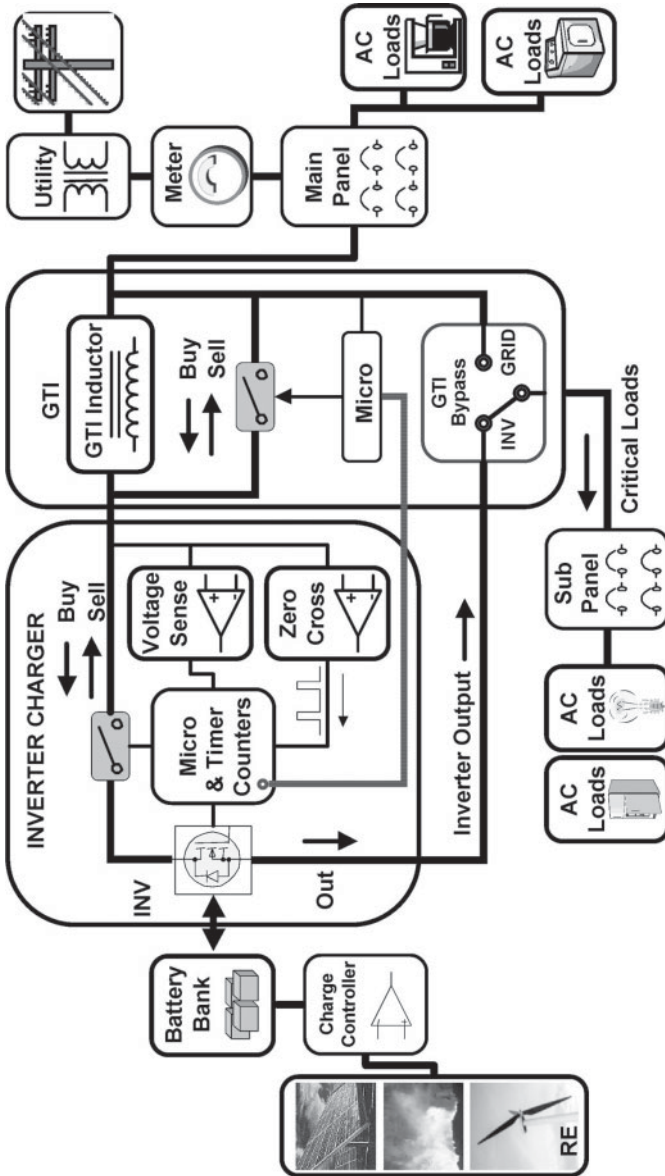

Figure 1-1  
Grid Tie Interface Flow Diagram



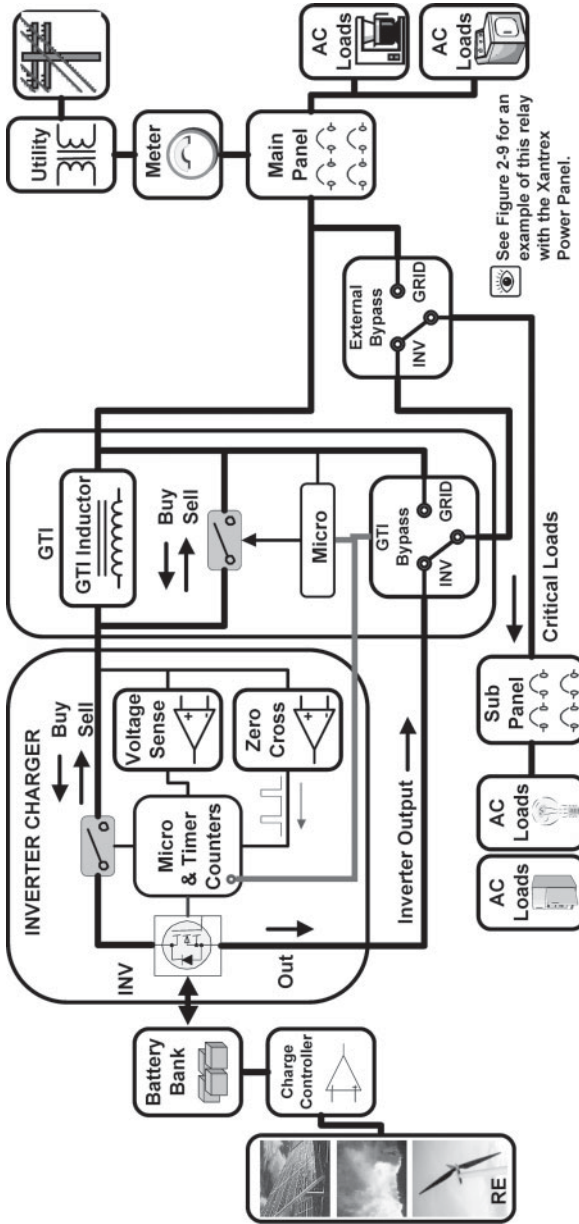

Figure 1-2  
Grid Tie Interface Flow Diagram with External Manual Bypass Switch

---

# 1.0 INTRODUCTION

---

## STANDARD FEATURES

The Grid Tie Interface (GTI) is an external unit that is required for use with the Xantrex SW Series Inverters, models SW4024, SW4048, and SW5548 with Rev. 4.2 firmware or higher, being used in Utility Interactive “Sell” mode. This device ensures compliance with regulatory standards for utility interface applications.

The GTI utilizes a highly-efficient inductor constructed of high temperature materials and M-6 grade steel laminations, meeting UL Class-H standards.

The unit is housed in a powder-coated, steel enclosure, suitable for indoor installations and contains dual knockouts for ¾" - 1" and ½" - ¾" conduit connections. The unit includes a control board with one 10-pin, polarized, connector that connects to the SW inverter.

The GTI has two functions: 1) Utility Interactive Mode, and 2) Bypass Mode.

### Utility Interactive Mode

Utility Interactive Mode is only engaged when the SW inverter begins selling power in the “Sell” mode. When in this mode, the GTI engages an inductor through an internal relay that filters out current harmonics and ensures that the power transferred to the grid has Total Harmonic Distortion (THD) levels that are within acceptable ranges and ensures the power factor is high. The GTI also provides anti-islanding protection in the event of a utility grid failure.

### Bypass Mode

The GTI includes a bypass relay that is controlled by the current direction and levels in the GTI and allows the critical loads to be connected to the grid or to the output of the SW inverter. When a low level “sell” current begins, the GTI will engage the bypass relay to allow the loads to be connected to the grid. In this operation (grid-connected), the inverter’s AC1 relay and the bypass relay work together to ensure fast transfer of the critical loads in a backup situation.

The critical loads are effectively connected directly to the grid – through the GTI – rather than passing through the inverter, resulting in the “LOAD AMPS AC” menu item displayed on the SW inverter to read zero. This zero reading will continue until the inverter batteries require a “buy” current of 10-15 amps AC or if a loss of grid power is detected. If either one of these conditions is detected, the bypass relay will engage to allow the critical loads to be directly powered by the inverter (inverter-connected). The inverter will continue to power the critical loads until another “sell” current begins, which again switches to the grid-connected operation.



**Figure 1-3**  
**Grid Tie Interface Unit**

### PRE-INSTALLATION

The GTI is only designed to work with the SW4024, SW4048 and SW5548 models that have revision 4.2 (or higher) software. Prior to installing the GTI, ensure that you have the appropriate model, the proper level of software and the inverter has the communication cable located within.



See Figure 2-6 for the location of this cable.



---

**WARNING: THE CRITICAL LOADS ARE NOW POWERED THROUGH THE GTI; THESE LOADS WILL NOT BE POWERED IF THE SW INVERTER OR THE GTI ARE OFF OR DISCONNECTED. IT IS RECOMMENDED THAT AN EXTERNAL BYPASS SWITCH/BREAKER BE INSTALLED BETWEEN THE GRID AND THE CRITICAL LOAD-PANEL. THIS SWITCH, WHEN ENGAGED, WILL ALLOW THE GRID TO DIRECTLY POWER THE LOADS WHILE THE GTI OR SW INVERTER IS OFF OR DISCONNECTED. SEE FIGURE 2-9 FOR AN EXAMPLE OF THIS RELAY IN A XANTREX POWER PANEL.**

---

### Required Tools and Materials

- Wire strippers
- Phillips screw driver
- Slotted screw driver
- Torque wrench
- 3/16" Hex-Head wrench
- #6 AWG Wire

### Removing the Top Cover

1. Remove the four Phillips screws and starwashers and set aside. Be sure to put these screws and washers somewhere where they can't get lost.



**Figure 2-1**  
**Removing the Top Cover**

---

## 2.0 INSTALLATION

---

### MOUNTING

Place the GTI in a convenient location, close to the inverter. The GTI must be mounted horizontally on a flat surface (such as a wall) in a clean, dry environment. Do not mount the GTI where it will be exposed to the weather or in a damp location.



**NOTE:** *The GTI weighs approximately 25 pounds. Use appropriate wall anchors or backing material (plywood, 2 x 4's, etc.) that will support its weight.*



**CAUTION:** *Do not mount vertically as water may enter the enclosure and damage the internal circuitry. Damage caused by mounting the unit vertically is NOT covered under the limited warranty.*

### Procedure

1. Use a level and mark the location for mounting the unit on the wall.
2. Measure out the four mounting screw holes according to Figure 2-3.
3. Use a #10 x 3/8 (or 1/2) inch long screw and washer (and appropriate anchors if necessary) and mount the GTI securely to the wall or backing material (plywood, 2 x 4's, etc.).
4. Remove the appropriate knockouts for the conduit. Install the conduit between the GTI and the inverter. Use separate conduit for the AC wiring and the communications cable.

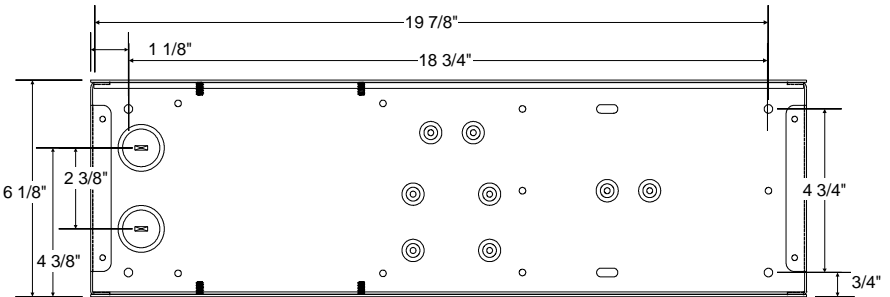

**Figure 2-2**  
**Mounting Holes**

---

## 2.0 INSTALLATION

---



**Front Internal view of unit**

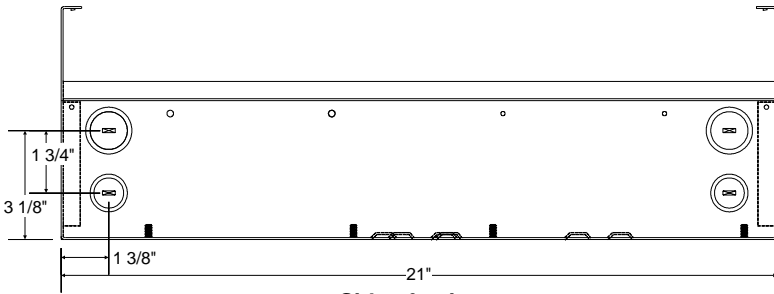

**Side of unit**

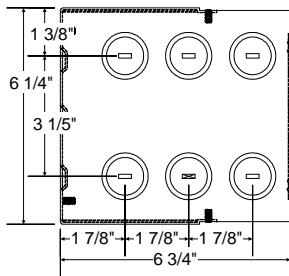

**Ends of unit (both ends)**

**Figure 2-3**  
**Dimensional Drawing (Not to scale)**

---

## 2.0 INSTALLATION

---

### WIRING

#### AC Wiring for Single-Inverter Installations

 **NOTE:** All wiring should be performed by a qualified person or a licensed electrician.

 **NOTE:** Ensure that wire size and conduit sizes are appropriate for this installation. AC wiring should be routed in separate conduits from the communications cable.

 **CAUTION:** AC pass-through ability through the GTI is 60 amps. It is recommended to use minimum #6 AWG (THHN) wiring.

 See Figure 2-7 for an enlargement of this circuit board showing the location of the communications cable port.

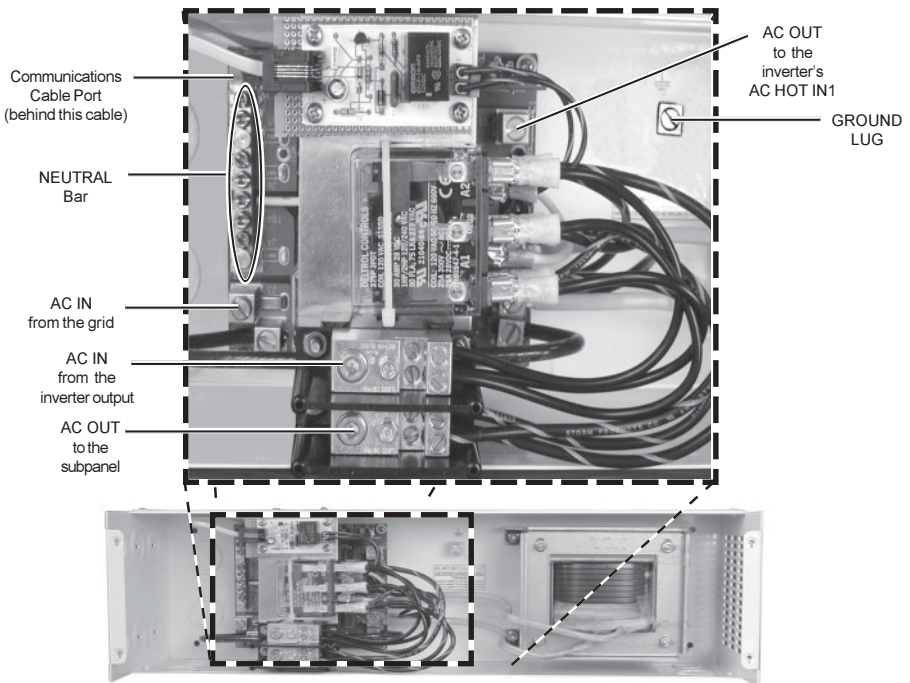

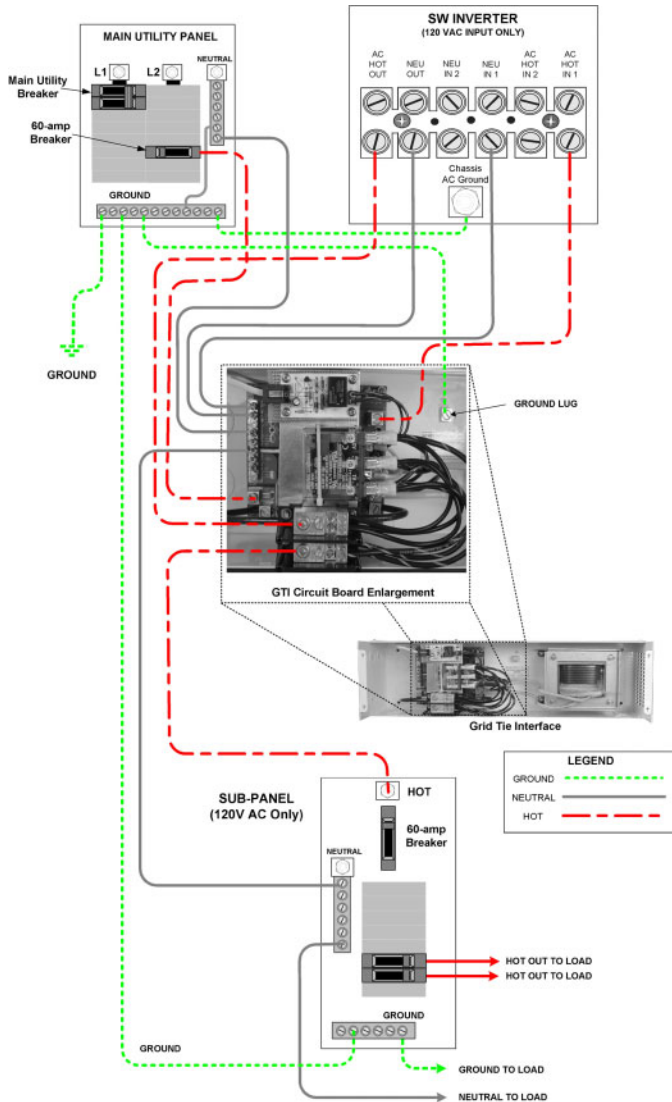

Figure 2-4  
GTI Circuit Board Enlargement

## 2.0 INSTALLATION

### AC Wiring for Single-Inverter Installations (continued)

 See pages 10 through 21 for detailed instructions for AC Input and AC output wiring for single-inverter/GTI installations.



**Figure 2-5**  
AC Input and Output Wiring for Single-Inverter Installations

---

## 2.0 INSTALLATION

---

### Wiring (continued)

#### AC Wiring for Single-Inverter Installations (continued)

##### Ground Wiring



---

*Note: Ground wiring must be established at each unit. Ground wiring can also be accomplished in a variety of ways. The following instructions describe only one method. Please consult your local electrician for specific wiring details pertaining to your installation.*

---

1. Connect a wire from the ground bus in the main service panel to the ground lug in the GTI.
2. Connect a wire from the ground bus in the main service panel to the ground terminal in the inverter.
3. Connect a wire from the ground bus in the main service panel to the ground terminal in the sub-panel.



See Figure 2-5a for an illustration of ground wiring for a single-inverter installation with the GTI.



## 2.0 INSTALLATION

### AC Wiring for Single-Inverter Installations (continued)

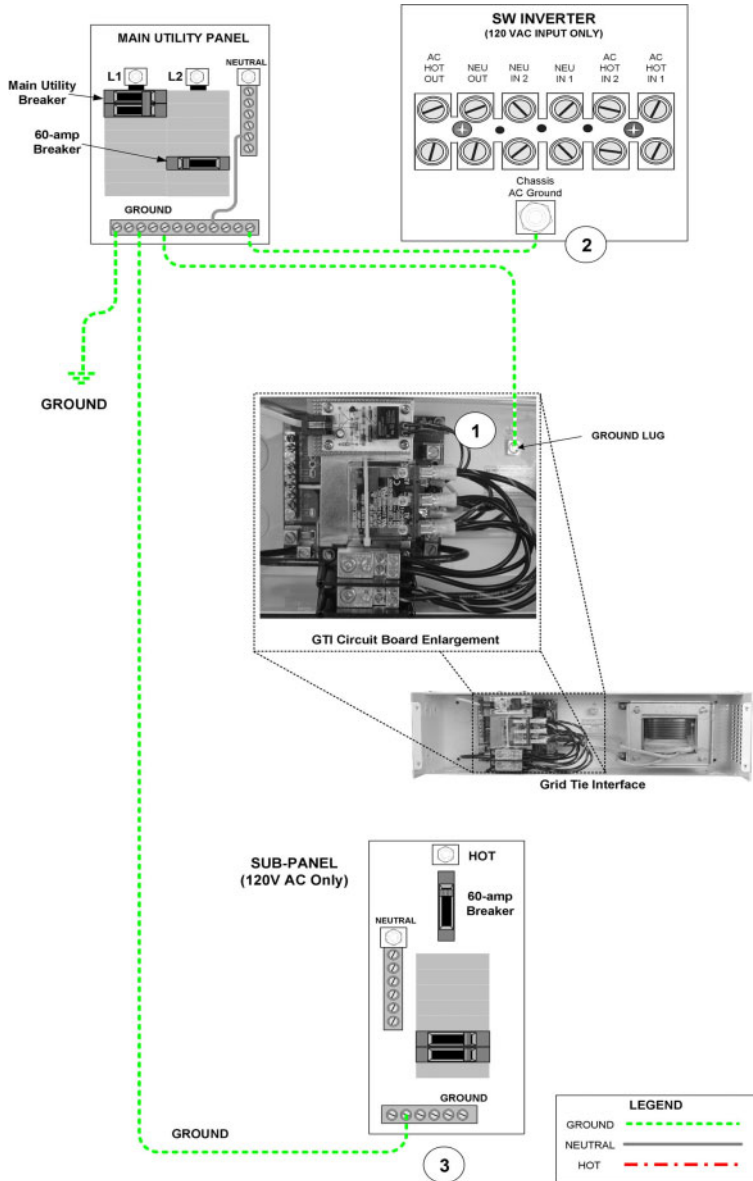

Figure 2-5a  
Ground Wiring for a Single-Inverter Installations

---

## 2.0 INSTALLATION

---

### Wiring (continued)

#### AC Wiring for Single-Inverter Installations (continued)

##### Utility Grid AC Wiring to the GTI



**WARNING: DISCONNECT THE BATTERIES FROM THE INVERTER IF THEY ARE ALREADY CONNECTED.**

1. Ensure the breaker that feeds the GTI is OFF (i.e., no power out). Feed the HOT and NEUTRAL input wires from the GTI to the main utility panel. Leave a sufficient amount of extra wire at each end.
2. Confirm a GROUND (green) wire exists from the main utility panel to the GTI's AC GROUND lug.
3. Connect the NEUTRAL (white) wire from the main utility panel to the GTI's NEUTRAL bar.
4. Connect the HOT (BLACK) wire from a single-pole breaker (60 amps) in the main utility panel to the GTI's AC1 HOT IN terminal.
5. Torque all connections to 10 to 15 inch-pounds.



See Figure 2-5b for an illustration of Utility Grid AC Wiring to the GTI.

### AC Wiring for Single-Inverter Installations (continued)

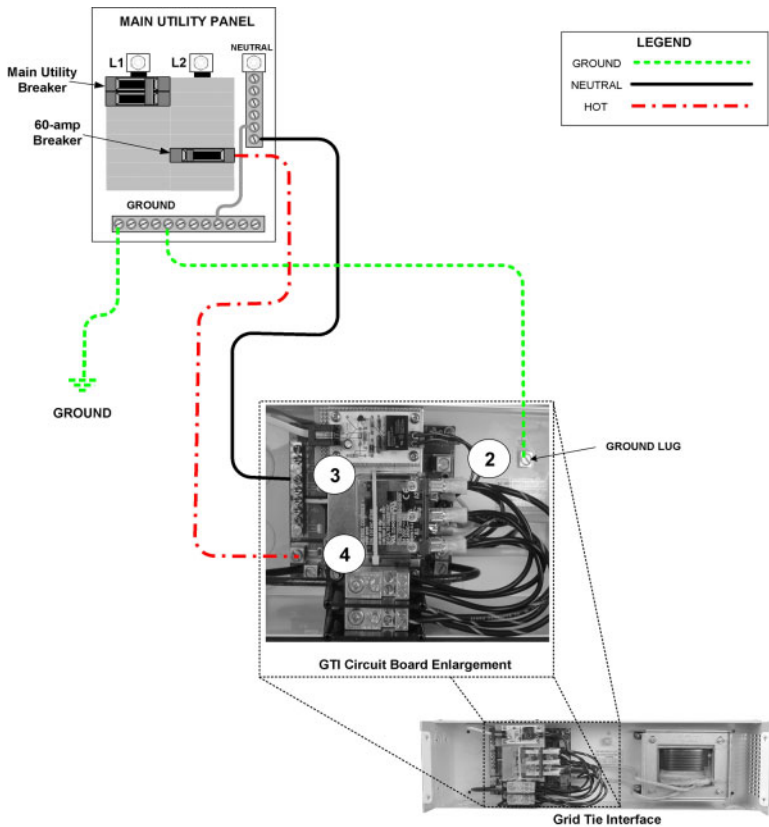

Figure 2-5b  
Utility Grid AC Wiring to the GTI

---

## 2.0 INSTALLATION

---

### Wiring (continued)

#### AC Wiring for Single-Inverter Installations (continued)

##### Inverter AC Input Wiring to the GTI

1. Feed the HOT and NEUTRAL input wires from the inverter to the GTI.  
Leave three to six inches of extra wire at each end.
2. Connect the NEUTRAL (white) wire from the GTI's NEU OUT terminal to the inverter's NEUTRAL IN 1 terminal.
3. Connect the AC1 HOT OUT (BLACK) wire from the GTI to the inverter's AC1 HOT IN terminal.
4. Torque all connections to 10 to 15 inch-pounds.



See Figure 2-5c for an illustration of the inverter AC input wiring to the GTI.

### AC Wiring for Single-Inverter Installations (continued)

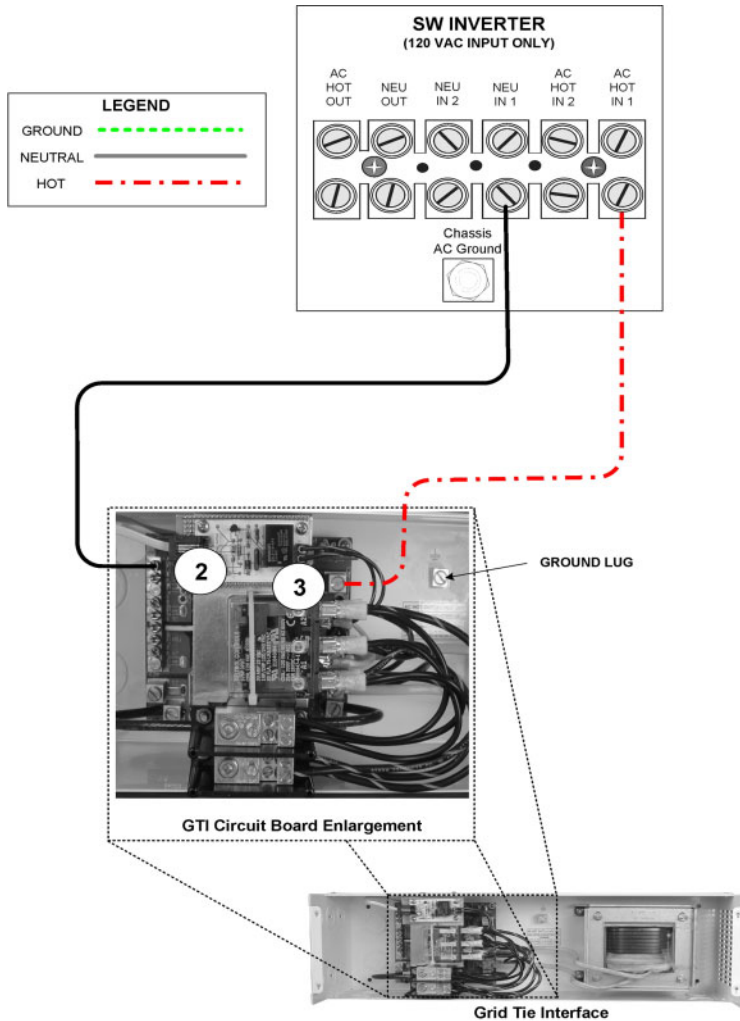

**Figure 2-5c**  
Inverter AC Input Wiring to the GTI

---

## 2.0 INSTALLATION

---

### Wiring (continued)

#### AC Wiring for Single-Inverter Installations (continued)

##### Inverter AC Output Wiring to the GTI



**WARNING: ENSURE THE SUB-PANEL DOES NOT HAVE A NEUTRAL-TO-GROUND BOND. IF IT DOES, REMOVE IT. ALL AC NEUTRAL-GROUND BONDING IS DONE AT THE MAIN UTILITY PANEL.**

---

1. Connect a NEUTRAL (white) wire to the inverter's NEUTRAL OUT terminal.
2. Connect the other end of this same NEUTRAL wire to the NEUTRAL bar in the GTI.
3. Connect a HOT (Black) wire to the inverter's terminal labeled AC HOT OUTPUT.
4. Connect the other end of the HOT (black) wire from the inverter's AC HOT OUT terminal to the GTI's HOT IN terminal.
5. Torque all connections to 10 to 15 inch-pounds.



See Figure 2-5d for an illustration of the inverter AC output wiring to the GTI.

### AC Wiring for Single-Inverter Installations (continued)

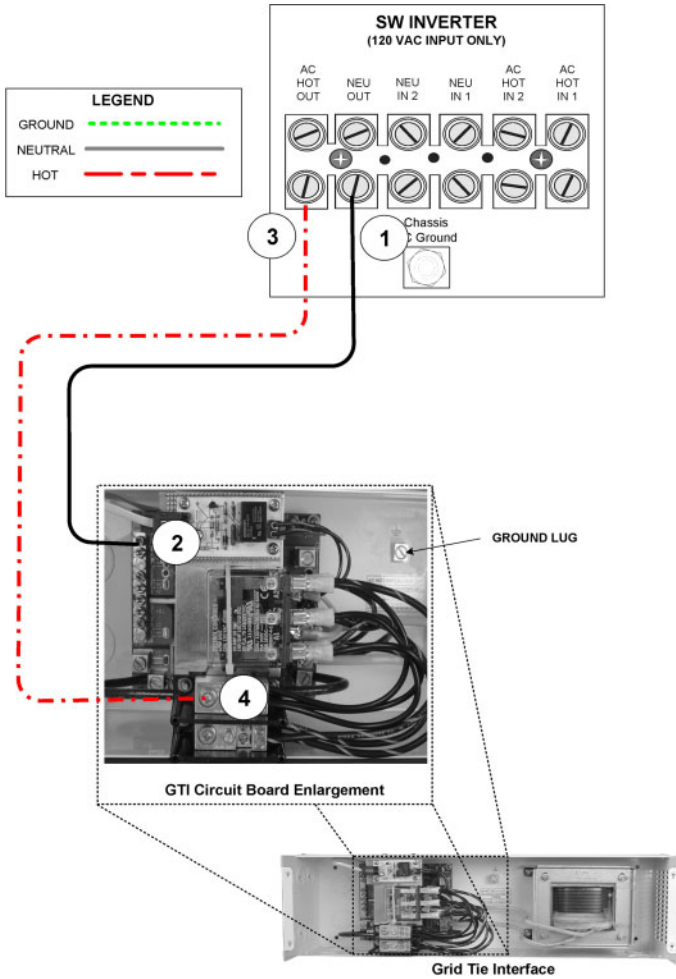

Figure 2-5d  
Inverter AC Output Wiring to the GTI

---

## 2.0 INSTALLATION

---

### Wiring (continued)

#### AC Wiring for Single-Inverter Installations (continued)

##### GTI Wiring to the Sub-Panel



---

**WARNING: ENSURE THE SUB-PANEL DOES NOT HAVE A NEUTRAL-TO-GROUND BOND. IF IT DOES, REMOVE IT. ALL AC NEUTRAL-GROUND BONDING IS DONE AT THE MAIN UTILITY PANEL.**

---

1. Connect a NEUTRAL (white) wire to the GTI's NEUTRAL bar.
2. Connect the other end of this NEUTRAL wire to the NEUTRAL bar in the sub-panel.
3. Connect the HOT (black) wire to the GTI's AC HOT OUT terminal.
4. Connect the other end of this HOT (black) wire to the sub-panels HOT IN terminal.
5. Torque all the inverter's connections to 10 to 15 inch-pounds.



---

*NOTE: Consult the sub-panel manufacturer's specifications for wire torques on the sub-panel connections. Use those torque requirements if different.*

---



### AC Wiring for Single-Inverter Installations (continued)

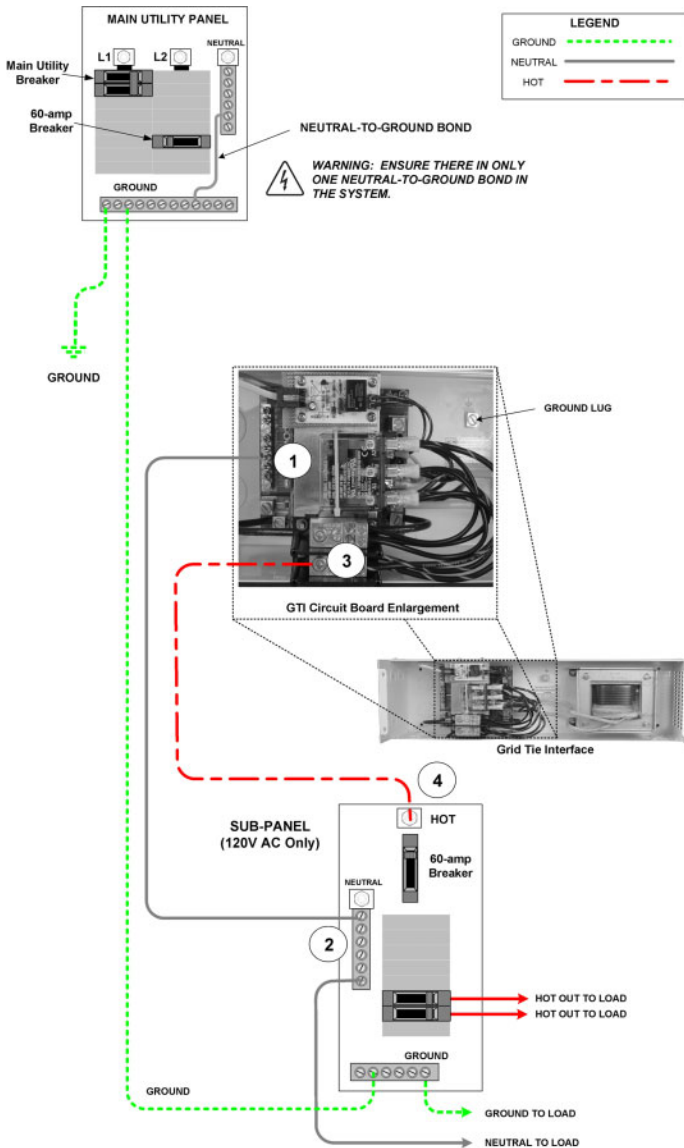

**Figure 2-5e**  
**GTI Wiring to the Sub-Panel**

---

## 2.0 INSTALLATION

---

### Wiring (continued)

#### Communications Cable

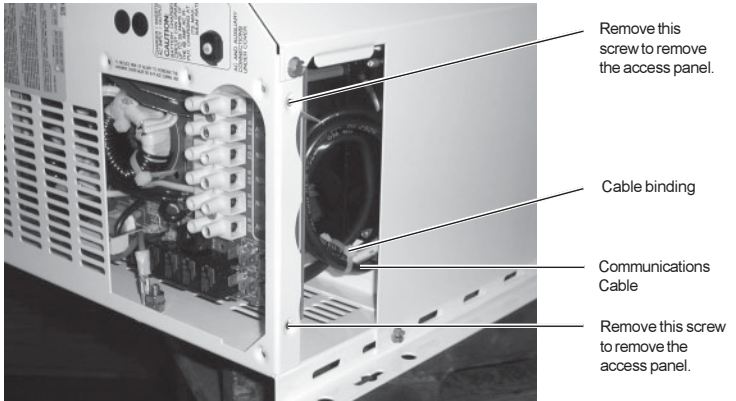

**Figure 2-6**  
**GTI Communications Cable Location**

1. Remove the access panel on the bottom of the inverter.
2. Clip the cable binding and gently remove the loose end of the communications cable from inside of the inverter. It will be located directly behind the AC Terminal Block. This cable extends approximately 2.5 feet out of the inverter.
3. Connect the loose end of the communications cable to the communications cable port on the GTI circuit board.



See Figure 2-7 for the location of the communications port inside the GTI.

### Wiring (continued)

### Communications Cable (continued)

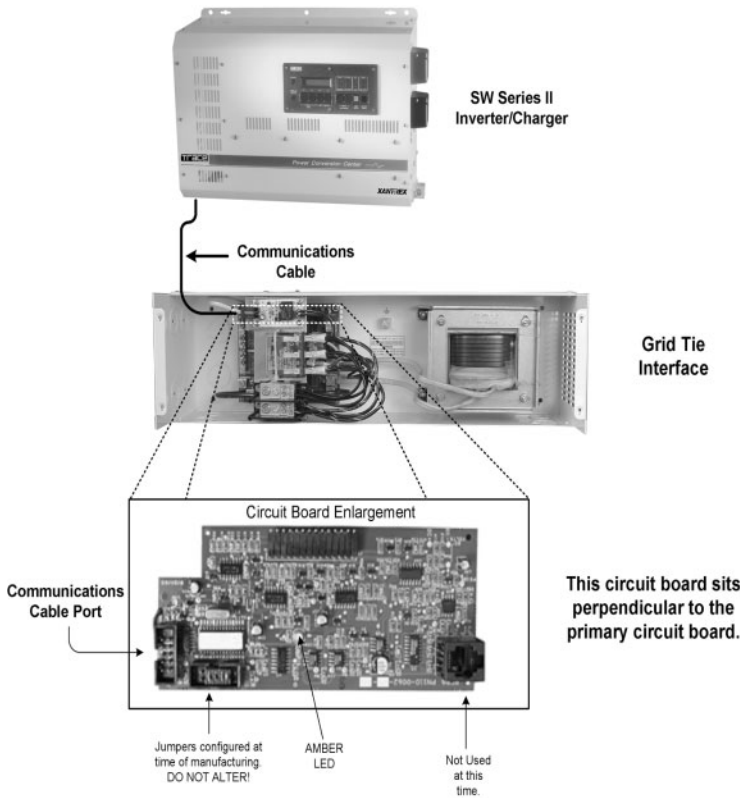

**Figure 2-7**  
Connecting the Communications Cable to the Circuit Board

---

 **NOTE:** An additional 8-foot 10-conductor extension cable is available at Xantrex (P/N 130-0118-01-01) for installations where the inverter is more than 2 feet away from the GTI.

---

---

## 2.0 INSTALLATION

---

### Wiring (continued)

#### AC Wiring for Dual-Inverter Installations

Series stacking is used in applications where either 240-volt loads (or a combination of both 240- and 120-volt loads) need to be powered from the inverters. One inverter, connected to the utility's L1 line, provides one 120 volt AC output and a second inverter connected to the utility's L2 line provides the second 120 volt AC output (180 degrees out-of-phase from the first inverter). The combined out-of-phase voltages can power 240 volt AC loads as well as 120 volt loads, up to the power rating of the inverters.



*NOTE: For full pass-through capability of the inverter, #6 AWG (90°C) minimum is recommended. Protect the wire with an appropriately sized breaker.*

---



See Figure 2-8 for an illustration of input and output wiring for dual-inverters with dual GTI installations.



See pages 24 through 31 for detailed instructions for AC Input and AC output wiring for dual-inverter/GTI installations.

### AC Wiring for Dual-Inverter Installations (continued)

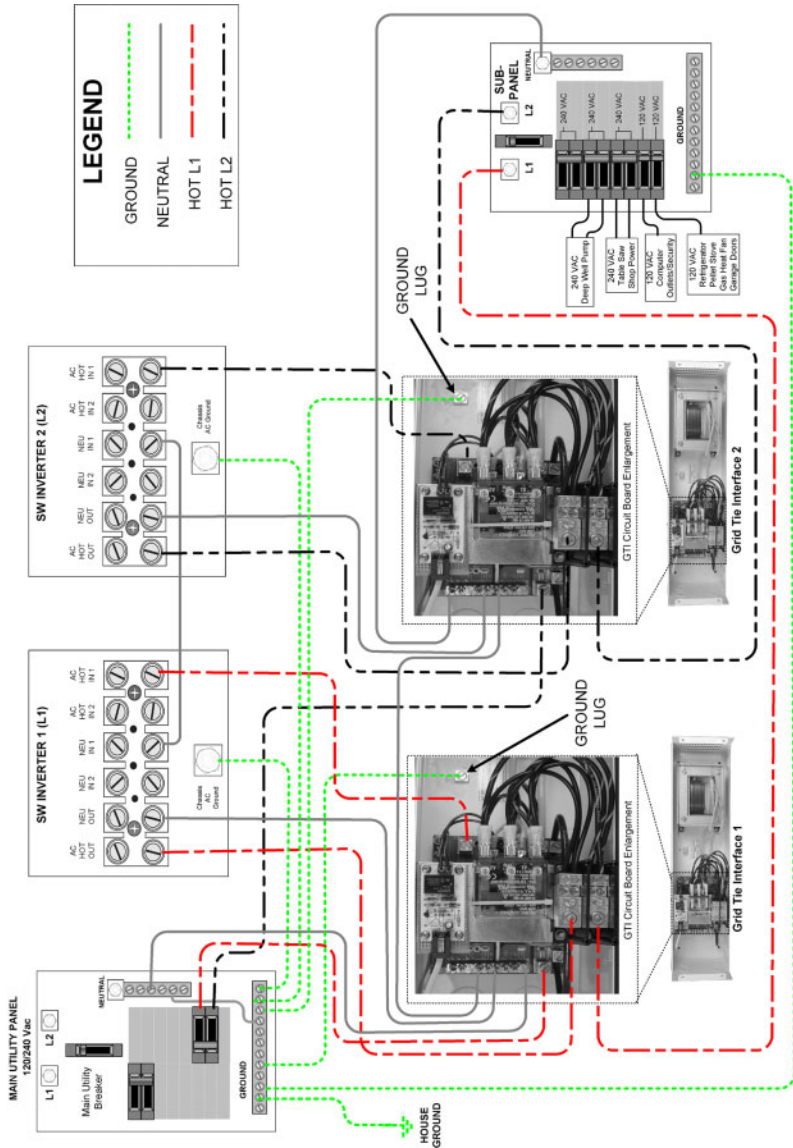

Figure 2-8  
Wiring Diagram for Dual Inverter Installations

---

## 2.0 INSTALLATION

---

### Wiring (continued)

#### AC Wiring for Dual-Inverter Installations (continued)

##### Ground Wiring

1. Ensure there is a ground wire from inverter-1 to the main service panel.
2. Ensure there is a ground wire from inverter-2 to the main service panel.
3. Connect a wire from the ground bus in the main service panel to the GROUND terminal in the GTI-1.
4. Connect a wire from the ground bus in the main service panel to the GROUND terminal in the GTI-2.
5. Connect a wire from the ground bus in the main service panel to the GROUND terminal in the sub-panel.



See Figure 2-8a for an illustration of the ground wiring for dual-inverter/dual-GTI installations.

### AC Wiring for Dual-Inverter Installations (continued)

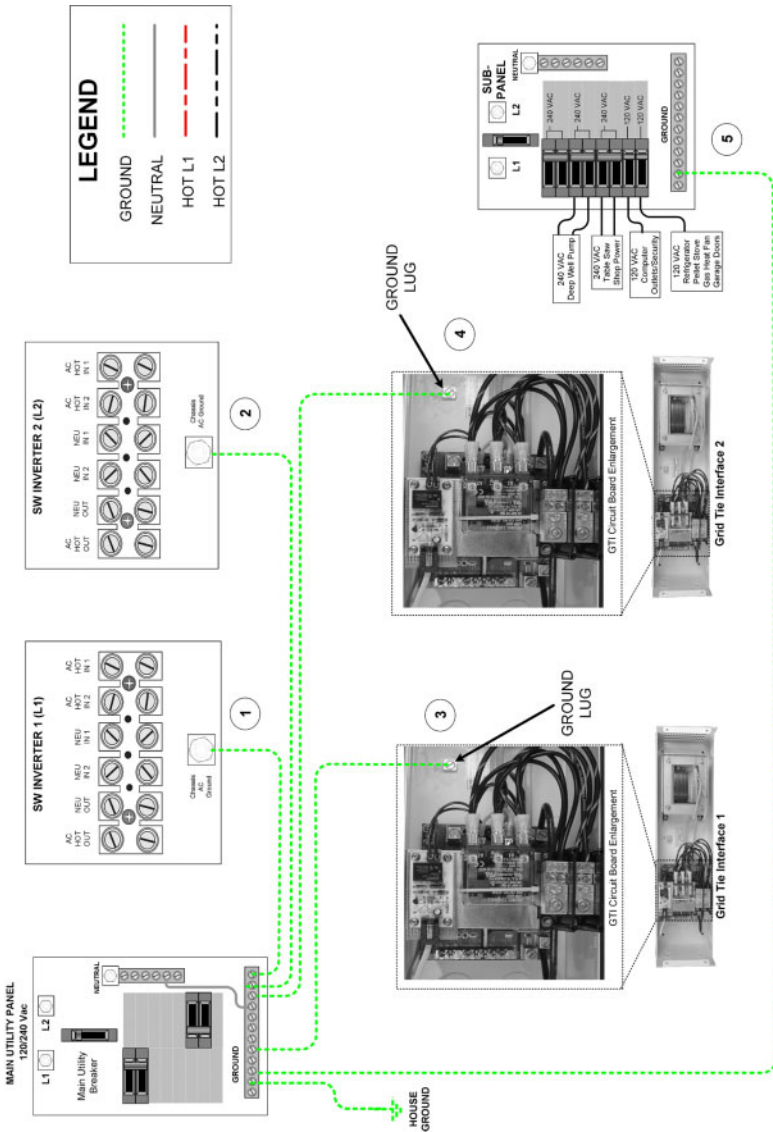

Figure 2-8a  
Ground Wiring for Dual-Inverter Installations

---

## 2.0 INSTALLATION

---

### Wiring (continued)

#### AC Wiring for Dual-Inverter Installations (continued)

##### Utility Grid AC Wiring to Dual GTIs

1. Connect a wire from the neutral bus in the main service panel to the NEUTRAL bar in the GTI-1.
2. Connect a wire to the NEUTRAL bar on the GTI-1 and route this wire to the GTI-2's NEUTRAL bar. Keep this wire as short as possible.
3. Select a dual-pole breaker in the main service panel. Connect a wire from the L1-pole of the selected breaker to the GTI-1's AC HOT IN terminal.
4. Connect a wire from the L2 pole of the same dual-pole breaker to the GTI-2's AC HOT IN terminal.



See Figure 2-8b for an illustration of AC wiring from the utility grid to the GTIs.



### Wiring (continued)

### AC Wiring for Dual-Inverter Installations (continued)

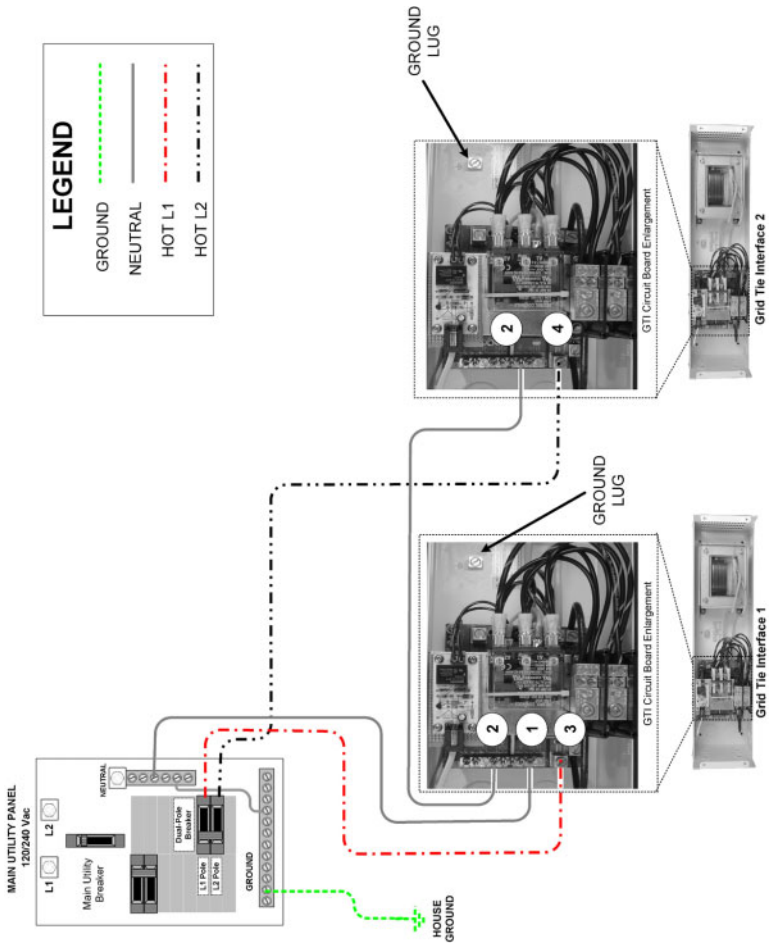

Figure 2-8b  
Utility Grid AC Wiring to Dual GTIs

---

## 2.0 INSTALLATION

---

### Wiring (continued)

#### AC Wiring for Dual-Inverter Installations (continued)

##### Inverter AC Input and Output Wiring to the GTIs

The output of each inverter provides 120 Vac. The voltage between the HOT outputs from the L1 and L2 inverter is 240 Vac.



*NOTE: Both inverter AC IN and inverter AC OUT will be wired to the GTIs.*

1. Connect a wire from the GTI-1's AC HOT OUT to the L1 inverter's AC HOT IN 1 terminal.
2. Connect a wire from the GTI-2's AC HOT OUT to the L2 inverter's AC HOT IN 1 terminal.
3. Connect the AC HOT OUTPUT (120 Vac) from the L1 inverter to the AC IN terminal in the GTI-1.
4. Connect the NEUTRAL wire from the L1 inverter's NEUTRAL OUT terminal to the neutral bar in the GTI-1.
5. Connect the AC HOT OUTPUT (120 Vac) from the L2 inverter to the AC IN terminal in the GTI-2.
6. Connect the NEUTRAL wire from the L2 inverter's NEUTRAL OUT terminal to the neutral bar in the GTI-2.
7. Connect a wire from the NEUTRAL bar in GTI-1 to the NEUTRAL bar in GTI-2.
8. Ensure a NEUTRAL wire exists from the L1 inverter NEUTRAL IN 1 terminal to the L2 inverter NEUTRAL IN 1 terminal.



See Figure 2-8c for an illustration of AC wiring from the inverters to the GTIs.

## AC Wiring for Dual-Inverter Installations (continued)

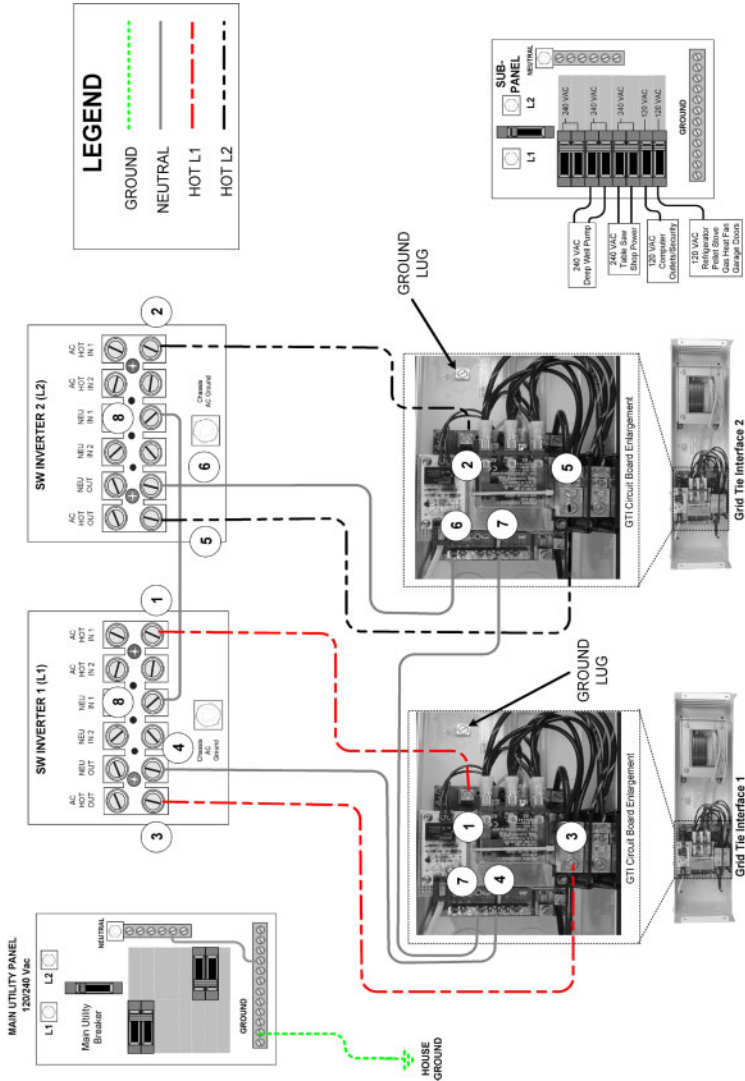

Figure 2-8c  
Inverter AC Input and Output Wiring to the GTIs

---

## 2.0 INSTALLATION

---

### Wiring (continued)

#### AC Wiring for Dual-Inverter Installations (continued)

##### GTI Wiring to the Sub-Panel

1. Connect a NEUTRAL wire from GTI-2's NEUTRAL bar to the NEUTRAL bar in the sub-panel.
2. Connect the AC OUTPUT (120 Vac) from GTI-1 to the L1 terminal in the sub-panel.
3. Connect the AC OUTPUT (120 Vac) from the GTI-2 to the L2 terminal in the sub-panel.



**WARNING: ENSURE THE ONLY NEUTRAL-TO-GROUND BOND IS IN THE MAIN UTILITY PANEL. REMOVE ANY BONDING FROM THE SUB-PANEL IF IT IS PRESENT.**

---



See Figure 2-8d for an illustration of GTI Wiring to the Sub-Panel.

##### Connecting the Communications Cables for Dual Inverter Installations



See Figure 2-6 for the location of the communications cable inside the SW inverters.



See Figure 2-7 for the location of the communications port on the GTI circuit board.



**NOTE:** *The communications cables are not interchangeable. Make sure that you connect the communications cable from the inverter to the GTI that has that inverter's AC HOT IN 1 connection.*

---

1. Connect the communications cable from inverter 1 to the communications port on GTI-1.
2. Connect the communications cable from inverter 2 to the communications port on GTI-2.

### AC Wiring for Dual-Inverter Installations (continued)

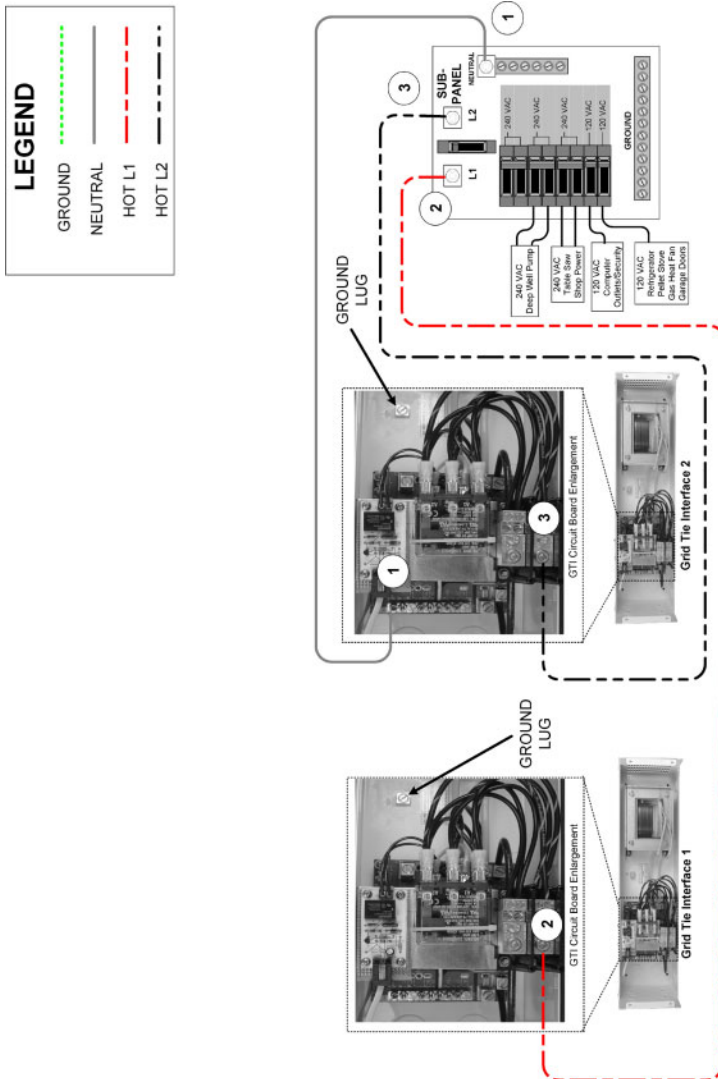

Figure 2-8d  
GTI Wiring to the Sub-Panel

---

## 2.0 INSTALLATION

---

### Wiring (continued)

#### AC Rewiring for Dual-Inverter Power Panel Installations



*NOTE: The following procedure is for a dual-inverter power panel system. If your system is only a single-inverter power panel system, disregard the steps that refer to components that are not present.*

---



*NOTE: Use appropriate sized wire and circuit breakers (if needed) for all wiring added to the installation. THHN #6 AWG wire is recommended.*

---

1. Inside the power panel, locate and label wires 1A and 1C from inverter-1 and wires 2A and 2C from inverter-2 as labeled in Figure 2-9.
2. Inside the power panel, locate and label terminals 1B, 1D, 2B and 2D as labeled in Figure 2-9.
3. Inside each GTI, locate and label the terminals 1B, 1D, 2B, and 2D as labeled in Figure 2-9.
4. Remove wire 1A from terminal 1B in the power panel.
  - a. Use a wire nut to add a sufficient length of wire to wire 1A to reach terminal 1A in GTI-1.
  - b. Connect the extended wire 1A to terminal 1A in GTI-1.
5. Remove wire 1C from terminal 1D in the power panel.
  - a. Use a wire nut to add a sufficient length of wire to wire 1C to reach terminal 1C in GTI-1.
  - b. Connect the extended wire 1C to terminal 1C in GTI-1.
6. Remove wire 2A from terminal 2B in the power panel.
  - a. Use a wire nut to add a sufficient length of wire to wire 2A to reach terminal 2A in GTI-1.
  - b. Connect the extended wire 2A to terminal 2A in GTI-2.
7. Remove wire 2C from terminal 2D in the power panel.
  - a. Use a wire nut to add a sufficient length of wire to wire 2C to reach terminal 2C in GTI-1.
  - b. Connect the extended wire 2C to terminal 2C in GTI-2.
8. Add a neutral wire (NEU) to the NEUTRAL BAR in GTI-1 and connect it to the NEUTRAL BAR in GTI-2.
9. Add a neutral wire (NEU) to the NEUTRAL BAR (NEU) in the power panel and connect it to either GTI-1 or GTI-2.
10. Add a wire to terminal 1B in the power panel and connect it to terminal 1B in GTI-1.
11. Add a wire to terminal 1D in the power panel and connect it to terminal 1D in GTI-1.
12. Add a wire to terminal 2B in the power panel and connect it to terminal 2B in GTI-2.
13. Add a wire to terminal 2D in the power panel and connect it to terminal 2D in GTI-2.

## 2.0 INSTALLATION

### AC Re-Wiring for Power Panel Installations (continued)

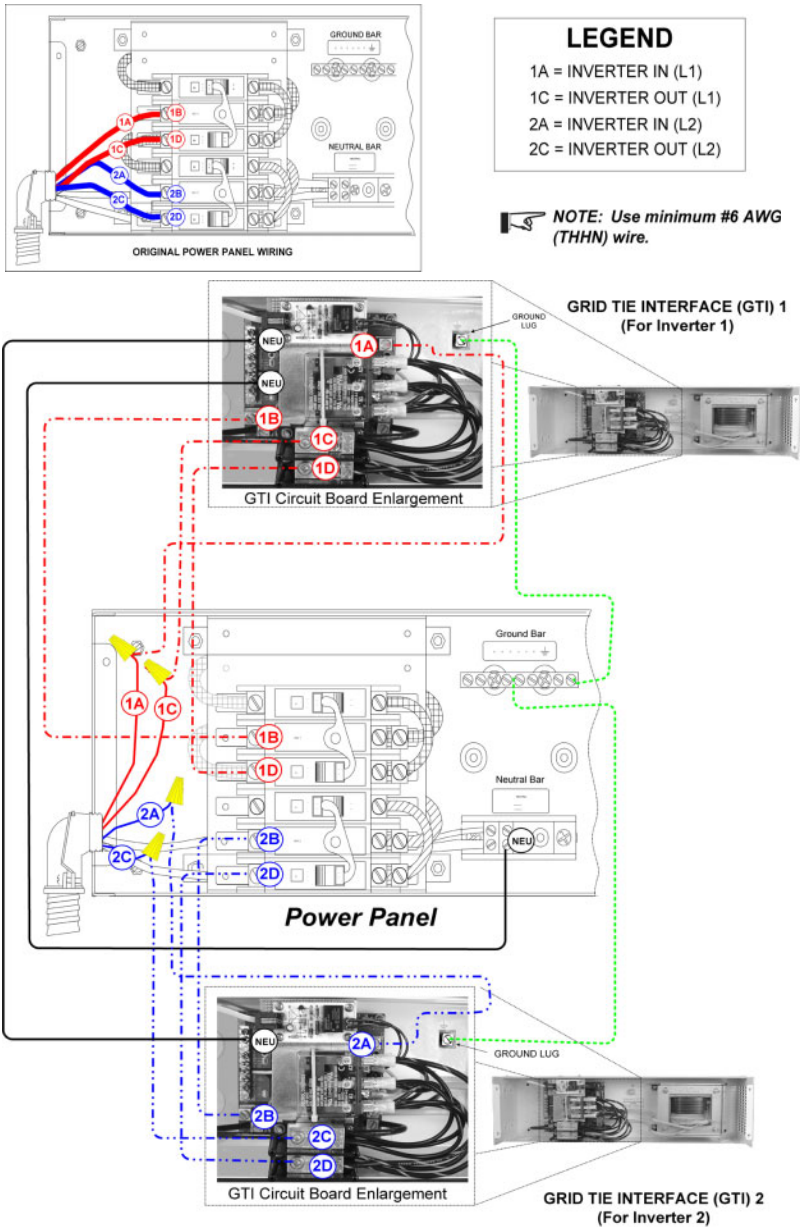

Figure 2-9  
Rewiring Power Panel Installations to include dual GTIs

---

## 2.0 INSTALLATION

---

### Wiring (continued)

#### AC Rewiring for Power Module Installations



*NOTE: The following procedure is for a dual-inverter power module system. If your system is only a single-inverter power module system, disregard the steps that refer to components that are not present.*



See Figure 2-10 for an illustration of the original power module wiring.



See Figure 2-10a for an illustration of the power module re-wiring.



*NOTE: Use appropriate sized wire and circuit breakers (if needed) for all wiring added to the installation. THHN #6 AWG wire is recommended.*

1. Inside the power module, locate and label wires 1A and 1C from inverter-1 and wires 2A and 2C from inverter 2 as labeled in Figure 2-10.
2. Inside the power module, locate and label terminals 1B, 1D, 2B and 2D as labeled in Figure 2-10.
3. Inside each GTI, locate and label the terminals 1B, 1D, 2B, and 2D as labeled in Figure 2-10a.
4. Remove wire 1A from terminal 1B in the power module.
  - a. Use a wire nut to add a sufficient length of wire to wire 1A to reach terminal 1A in GTI-1.
  - b. Connect the extended wire 1A to terminal 1A in GTI-1.
5. Remove wire 1C from terminal 1D in the power module.
  - a. Use a wire nut to add a sufficient length of wire to wire 1C to reach terminal 1C in GTI-1.
  - b. Connect the extended wire 1C to terminal 1C in GTI-1.
6. Remove wire 2A from terminal 2B in the power module.
  - a. Use a wire nut to add a sufficient length of wire to wire 2A to reach terminal 2A in GTI-2.
  - b. Connect the extended wire 2A to terminal 2A in GTI-2.
7. Remove wire 2C from terminal 2D in the power module.
  - a. Use a wire nut to add a sufficient length of wire to wire 2C to reach terminal 2C in GTI-2.
  - b. Connect the extended wire 2C to terminal 2C in GTI-2.
8. Add a neutral wire (NEU) to the NEUTRAL BAR in GTI-1 and connect it to the NEUTRAL BAR in GTI-2.
9. Add a neutral wire (NEU) to the NEUTRAL BAR (NEU) in the power module and connect it to either GTI-1 or GTI-2.



## 2.0 INSTALLATION

### AC Rewiring for Power Module Installations (continued)

10. Add a wire to terminal 1B in the power panel and connect it to terminal 1B in GTI-1.
11. Add a wire to terminal 1D in the power panel and connect it to terminal 1D in GTI-1.
12. Add a wire to terminal 2B in the power panel and connect it to terminal 2B in GTI-2.
13. Add a wire to terminal 2D in the power panel and connect it to terminal 2D in GTI-2.

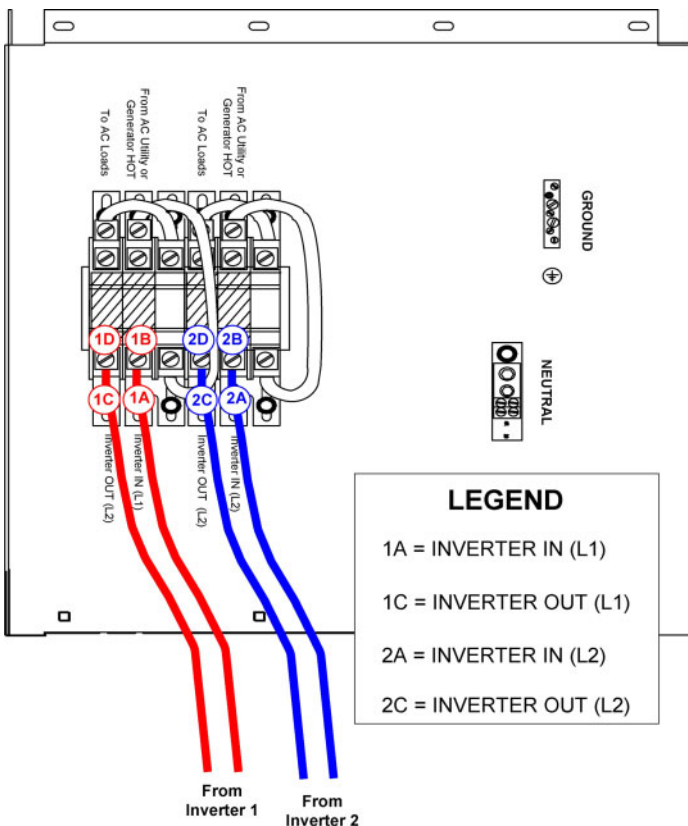

Figure 2-10  
Original Power Module Wiring

## 2.0 INSTALLATION

### Wiring (continued)

#### AC Rewiring for Power Module Installations (continued)

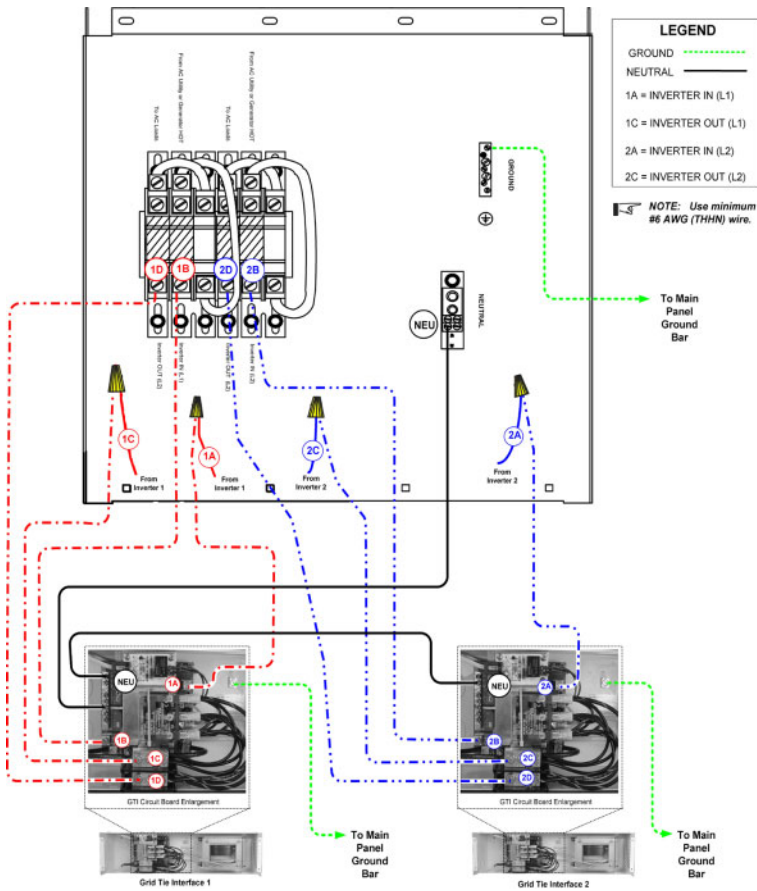

Figure 2-10a  
Power Module Re-wiring for dual GTI Installations

### WIRING CHECK

Before powering on the GTI, recheck all wiring and ensure it is connected to the proper terminals. Check that the ground and neutral connections are properly wired and tight.

After all the wiring has been checked, install the front cover and secure it with the four phillips screws removed in the beginning of the installation.

### OPERATING STACKED INVERTERS

Stacked inverters must operate together in order to provide the 120/240 Vac to the loads. The Series Stacking Interface cable ensures the output from each inverter is 180 degrees out-of-phase for operating 240 Vac loads.



*NOTE: Until the units are tested, do not connect loads to the inverters 120 or 240 Vac output.*

---

### START-UP AND TEST

1. Ensure the main service panel's circuit breakers feeding the inverters are OFF.
2. Switch ON both inverters. The inverter should be providing 120/240 Vac to the sub-panel.
3. Use an AC voltmeter and measure the voltage between the L1 terminal and neutral bus in the sub-panel. This voltage should be 120 Vac ( $\pm 3\%$ ).
4. Measure the voltage between the L2 terminal and neutral bus in the sub-panel. This voltage should be 120 Vac ( $\pm 3\%$ ).
5. Measure the voltage between the L1 and L2 terminals in the sub-panel. This voltage should be 240 Vac ( $\pm 3\%$ ).
6. Switch ON the main service panel's circuit breakers feeding the inverters.
7. Verify the inverters are charging the batteries and powering the sub-panel (refer to the operator's manual).
8. Switch both inverters OFF.
9. Replace all covers and panels on the inverters and sub-panel.

The stacked inverter system is now ready for use.



*NOTE: If the inverters are not operating properly, please refer to the operator's manual for setup and troubleshooting information.*

---

---

## 2.0 INSTALLATION

---

Notes:

## 3.0 TROUBLESHOOTING

Symptom	Recommended Action	Resolution
The system is not selling power to the grid and the inverter AC1 LED is flashing.	Ensure the inverter is on.	Turn the inverter on.
The system is not selling power to the grid and the inverter AC 1 LED is off.	Check wiring to the inverter and GTI input.	Correct the AC wiring.
<p><i>After checking the AC wiring:</i></p> <p>The system is still not selling power to the grid and the inverter AC1 LED is off.</p>	Remove the GTI cover and check the LED on the vertical circuit board.	See Figure 2-7 for the location of the LED.
	If the GTI LED is ON, the voltage and frequency are present.	There is no problem with the unit.
	If the GTI LED is flashing, the voltage and frequency are present, but not within acceptable UL limits.	After a 5-minute delay, the LED will turn on if the grid power has returned within acceptable limits.
	If the GTI LED is off, the voltage and frequency are not present at the GTI input.	Check the input breaker and AC wiring.

**Table 3-1**  
**Troubleshooting Guidelines for the Grid Tie Interface**

---

## 3.0 TROUBLESHOOTING

---

Notes:

---

## APPENDIX A – SPECIFICATIONS

---

### ELECTRICAL SPECIFICATIONS<sup>1</sup>

Utility Interactive Protection	Over/under AC voltage and frequency detection plus active islanding detection
AC Voltage (Nominal)	120 VAC
AC Voltage (Allowed)	
Utility Interactive Mode	106 - 132 VAC
Bypass mode/"Buy" Current	80-149 VAC
Input Frequency (Allowed)	
Utility Interactive Mode	59.3 - 60.5 Hz
Bypass Mode/"Buy" Current	53.0 - 67.0 Hz
AC Current (Allowed) (@ 25°C)	
Utility Interactive Mode	40 amps continuous
Bypass Mode/"Buy" Current	60 amps continuous
Total Output Harmonic Distortion	
Rated	<5% at rated power
Typical	2.5% at rated power

### MECHANICAL SPECIFICATIONS

Enclosure Type	Indoor, ventilated, steel chassis with white, powder-coat finish
Unit Weight	26 lb (15.9 kg)
Dimensions (H x W x D)	6.3" x 21" x 7" (16 cm x 53.3 cm x 17.8 cm)
Mounting	wall mount in a horizontal position only
AC Input/Output Terminals	Sized for #2-#14 AWG wires
Neutral Bar	Sized for #6 AWG wires
Conduit Sizes	Dual ¾" - 1" and ½" - ¾" knockouts

Specifications @ 25 °C  
Specifications subject to change without notice.



<sup>1</sup>All electrical specifications are based on the unit operating in the Utility Interactive Mode (SELL Mode selected) unless otherwise specified.

---





---

## APPENDIX B – PRODUCT AND SYSTEM INFORMATION

---

### WARRANTY

Xantrex Technology Inc., warrants its power products against defects in materials and workmanship for a period of two (2) years from the date of purchase, established by proof of purchase or formal warranty registration, and extends this warranty to all purchasers or owners of the product during the warranty period. Xantrex does not warrant its products from any and all defects:

- arising out of material or workmanship not provided by Xantrex or its Authorized Service Centers;
- when the product is installed or exposed to an unsuitable environment as evidenced by generalized corrosion or biological infestation;
- resulting from abnormal use of the product, alteration, or use in violation of the instructions;
- in components, parts, or products expressly warranted by another manufacturer.

Xantrex Technology Inc., agrees to supply all parts and labor to repair or replace defects covered by this warranty with parts or products of original or improved design, at the company's option. Xantrex Technology Inc., also reserves the right to improve the design of its products without obligation to modify or upgrade those previously manufactured. Defective products must be returned to Xantrex Technology Inc., or its Authorized Service Center in the original packaging or equivalent. The cost of transportation and insurance on items returned for service is the responsibility of the customer. Return transportation (UPS Ground or equivalent) as well as insurance on all repaired items is paid by Xantrex Technology Inc.

All remedies and the measure of damages are limited to the above. Xantrex Technology Inc., shall in no event be liable for consequential, incidental, contingent, or special damages, even if Xantrex Technology Inc., has been advised of the possibility of such damages. Any and all other warranties, expressed or implied, arising by law, course of dealing, course of performance, usage of trade or otherwise, including, but not limited to, implied warranties of merchantability and fitness for a particular purpose, are limited in duration for a period of two (2) years from the original date of purchase.

Some states or countries do not allow limitations on the term of an implied warranty, or the exclusion or limitation of incidental or consequential damage, which means the limitations and exclusions of this warranty may not apply to you. Even though this warranty gives you specific legal rights, you may also have other rights which vary from state to state.

---

## APPENDIX B – PRODUCT & SYSTEM INFORMATION

---

### RETURN MATERIAL AUTHORIZATION POLICY

You must obtain a Return Material Authorization (RMA) number from Xantrex before returning a product directly to Xantrex. Products returned without an RMA number or shipped collect will be refused. When you contact Xantrex to obtain service, be prepared to supply the serial number of your product and its date of purchase as well as information about the installation and use of the unit.

### Return Material Procedure

If you are returning a product, follow this procedure:

1. Obtain an RMA number and a shipping address from Xantrex.
2. Package the unit safely, preferably using the original box and packing materials. Include the following:
  - The RMA number
  - A copy of your dated proof of purchase
  - A return address where the repaired unit can be shipped
  - A contact telephone number
  - A brief description of the problem
3. Ship the unit freight prepaid to the address provided in step 1.

---

## APPENDIX B – PRODUCT & SYSTEM INFORMATION

---

### SERVICE INFORMATION

Xantrex Technology Inc., takes great pride in its products and makes every effort to ensure your unit fully meets your independent powering needs.

If your product needs repair, contact our Customer Service department at: (360) 435.8826 to obtain an RMA# and shipping information.

Please provide:

Model Number: \_\_\_\_\_

Serial Number: \_\_\_\_\_

Purchase Date: \_\_\_\_\_

Problem: \_\_\_\_\_

Include a telephone number where you can be reached during business hours and a complete return shipping address (P.O. Box numbers are not acceptable).

Name: \_\_\_\_\_

Address: \_\_\_\_\_

City: \_\_\_\_\_

State / Province: \_\_\_\_\_

Zip / Postal Code: \_\_\_\_\_

Country: \_\_\_\_\_

Phone: (\_\_\_\_) \_\_\_\_\_

FAX: (\_\_\_\_) \_\_\_\_\_

E-mail Address: \_\_\_\_\_

---

## APPENDIX B – PRODUCT & SYSTEM INFORMATION

---





**xantrex**

*Smart Choice for Power*

t 1 360 435 8826

f 1 360 435 2229

dpm@xantrex.com

www.xantrex.com